

# Barudan

HIGH SPEED AUTOMATIC EMBROIDERY MACHINE

MODEL

**BENSH-YN/YS**  
**BENRH-YN/YS**

## PARTS LIST

**BARUDAN CO., LTD.**

ADDRESS 906 JOSUIJI  
ICHINOMIYA-CITY·AICHI-PREF·  
JAPAN

TEL. <0586>76-1137

FAX. <0586>77-1499

製造元 **株式会社 バルダン**

営業本部/愛知県一宮市定水寺906

☎<0586>76-1137(大代表)

ファックス<0586>77-1499

本社/愛知県一宮市定水寺塚越20

☎<0586>76-6161(代表)

発売元 **バルダン販売株式会社**

愛知県一宮市定水寺塚越20

☎<0586>77-3959(代表)

ファックス<0586>77-6979





BENSH-YN/YS  
BENRH-YN/YS  
HIGH SPEED AUTOMATIC EMBROIDERY MACHINE  
高速自動刺繡マシン

C O N T E N T S  
目 次

Machine layout (BENSH-YN)  
配置図 (BENSH-YN)

- 00 Table・Flame  
テーブル・フレーム
- 01A Head・Bed A  
ヘッド・ベッドA
- 01B Head・Bed B  
ヘッド・ベッドB
- 02A Thread cut A  
糸切りA
- 02B Thread cut B  
糸切りB
- 02C Thread cut C  
糸切りC
- 02D Thread cut D  
糸切りD
- 03A Take up lever A  
天秤A
- 03B Take up lever B  
天秤B
- 04A Needle bar A  
針棒A
- 04B Needle bar B  
針棒B
- 04C Needle bar C  
針棒C
- 05 Jump  
ジャンプ
- 06A-1 Thread guide A (Standard) (YN)  
糸道A (標準)(YN)
- 06A-2 Thread guide A (Standard) (YS)  
糸道A (標準)(YS)

- 06B-1 Thread guide B (Lower thread sensorium)(YN)  
糸道 B (下糸検知)(Y N)
- 06B-2 Thread guide B (Lower thread sensorium)(YS)  
糸道 B (下糸検知)(Y S)
- 07A Color change A  
色換え A
- 07B Color change B  
色換え B
- 08A Drive A  
駆動 A
- 08B Drive B  
駆動 B
- 10A Pantograph drive A  
枠駆動 A
- 10B Pantograph drive B  
枠駆動 B
- 10C Pantograph drive C  
枠駆動 C
- 10D Pantograph drive D  
枠駆動 D
- 10E-1 Pantograph drive E(2 rails)  
枠駆動 E (2 本レール)
- 10E-2 Pantograph drive E(3 rails)  
枠駆動 E (3 本レール)
- 10F Pantograph drive F  
枠駆動 F
- 11-1 Control(NS)  
制御 (N S)
- 11-2 Control(NR)  
制御 (N R)
- 12 Accessories  
付属品

INDEX  
索引



Machine layout (BENSH-YN)

配置図 (BENSH-YN)

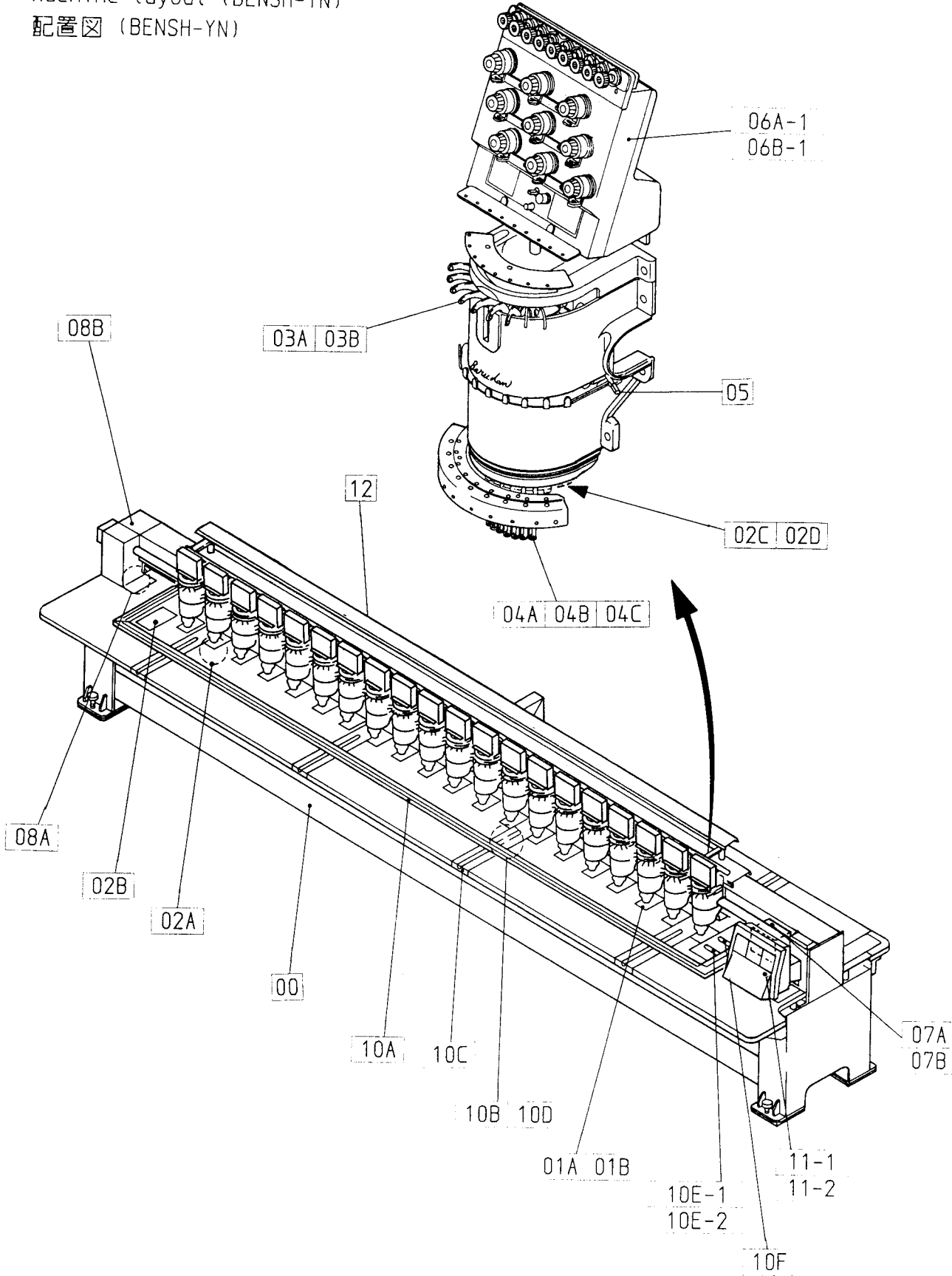

BENSH-YN/YS  
BENRH-YN/YS

00 Table・Flame  
 テーブル・フレーム

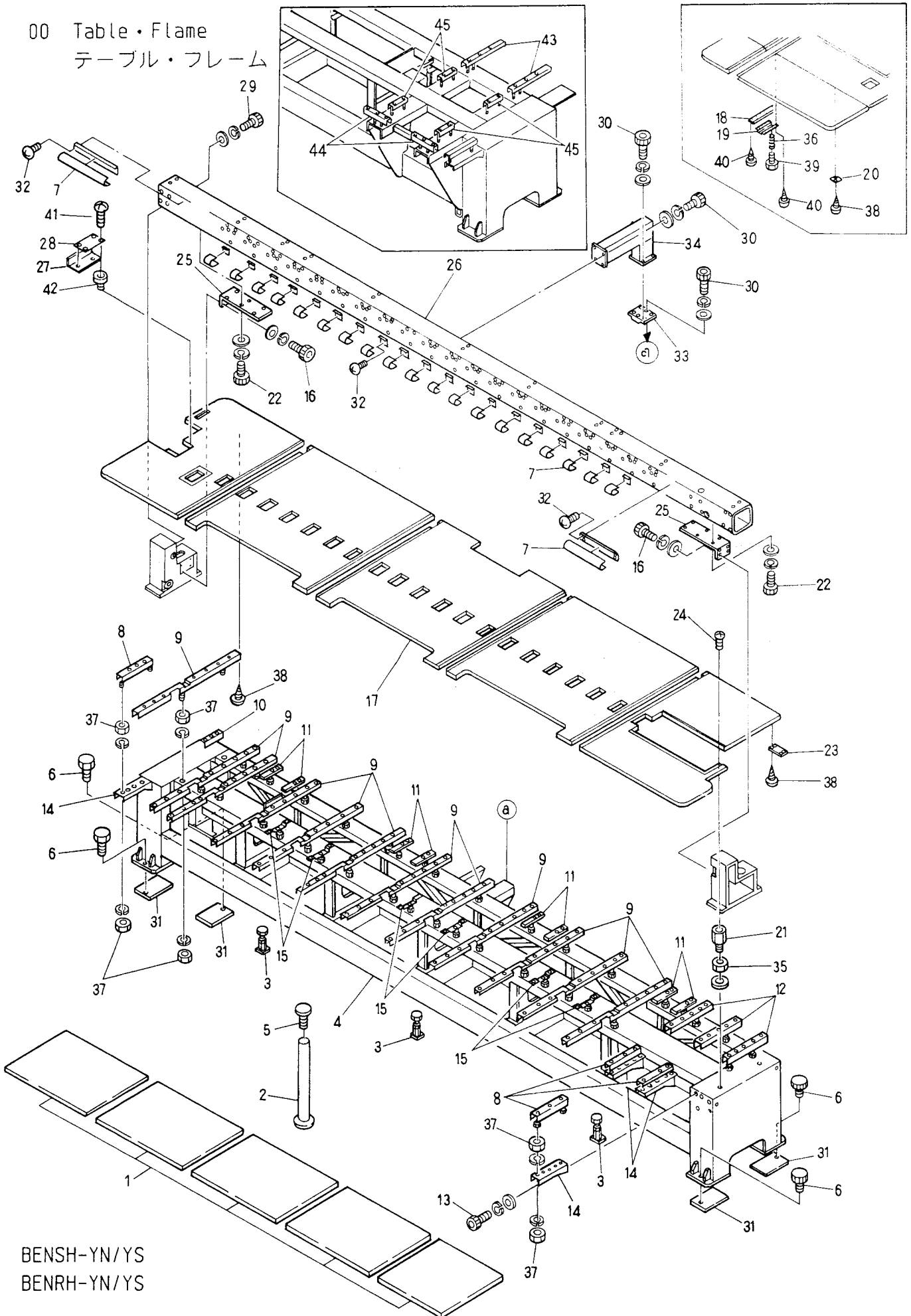

BENSH-YN/YS  
 BENRH-YN/YS



00 Table・Frame  
テーブル・フレーム

(※ Depends on machine type)

(※は機種によって異なる)

ITEM	LIST No.	DESCRIPTION	部品名	Q'TY	NOTE
1	1KHY3018560045H	Shelf board	棚板	1	※
2	WW140070	Table holder	テーブル支え	5	
3	HP120020	M16 Mid jack bolt	M16中間ジョッキボルト	6	
4	1AHB2024053045G	Frame	フレーム	1	※
5	A9012213	Level adjuster(C-1275-A-4)	レベルアジャスター-(C-1275-A-4)	5	
6		Hex. bolt M20×65	六角ボルト M20×65	4	
7	1SHB20240530J	Shaft cover morl YS-20 P=240/530	シャフトカバー モール YS-20 P=240/530	1	※
8	HP140111	Table support(310L)	テーブル受け(310)	4	※
9	HP141450	Table support(1169L) With notch	テーブル受け(1169L) 切り欠有	12	※
10	HH140260	Table support(215L)	テーブル受け(215L)	1	※
11	HP140841	Sub table support(215L)	補助テーブル受け(215L)	8	
12	HP140490	Table support(480L)	テーブル受け(480L)	4	※
13		Hex. socket bolt M8×20	六角穴付ボルト M8×20		
14	HP140120	Table support bracket	テーブル受けブラケット	4	
15	HP141080	Sub table support(230L)	補助テーブル受け(230L)	6	※
16		Hex. socket bolt M10×40	六角穴付ボルト M10×40		
17	1BHY3018560045H	Table	テーブル	1	※
18	HP14010085	Table support(H-Strok 7850)	テーブル支え(Hストローク 7850用)	1	
19	HP140090	Table support	テーブル支えサポート		
20	HP141090	Morable table support	脱着テーブルサポート		
21	HP140170	Table support bolt	テーブル受けボルト	1	
22		Hex. socket bolt M10×30	六角穴付ボルト M10×30		
23	KC140121	Table reinforcement plate	テーブル補助プレート	1	
24		Truss screw M6×35	十字穴付トラス小ネジ M6×35		
25	HP130021	Bridge support	ブリッジ受け	2	
26	1EHY3018560045H	Bridge	ブリッジ	1	※
27	HV310030	Shaft support cover	軸受けカバー	1	
28	HP321110	Lower shaft connecting coupling cover	下軸連結カップリングカバー	1	
29		Hex. socket bolt M12×40	六角穴付ボルト M12×40		
30		Hex. socket bolt M8×25	六角穴付ボルト M8×25		
31	HP120030	Base plate(200×200×t1)	ベースプレート(200×200×t1)	5	
32		Truss screw M5×10	十字穴付トラス小ネジ M5×10		
33	HB130040	Bridge support base(Center)	ブリッジ支えベース(センター部)	1	
34	HB13008045	Bridge support H-Strok 450	ブリッジ支え Hストローク 450	1	※
35		Hex. nut M8	六角ナット M8		
36	HH140940	Spring	テーブルサポート緩み止めバネ		
37		Hex. nut 3/8	六角ナット 3/8		
38		Truss bias biss M5×23	十字穴付ビスビス M5×23		
39		Hex. bolt M8×25	六角ボルト M8×25		
40		Wood screw M5.1×25	十字穴付丸木ネジ 5.1×25		
41		Truss screw M4×8(Undercut)	十字穴付トラス小ネジ M4×8(アンダーカット)		
42		Nut(C) M4	奥目ナット(C) M4		
43	HW140040	Table support(400L, P=70)	テーブル受け(400L, P=70)	2	
44	HW140050	Table support(240L, P=70)	テーブル受け(240L, P=70)	2	
45	HW140030	Table support(155L, P=135)	テーブル受け(155L, P=135)	4	

01A Head・Bed A  
 ヘッド・ベッドA

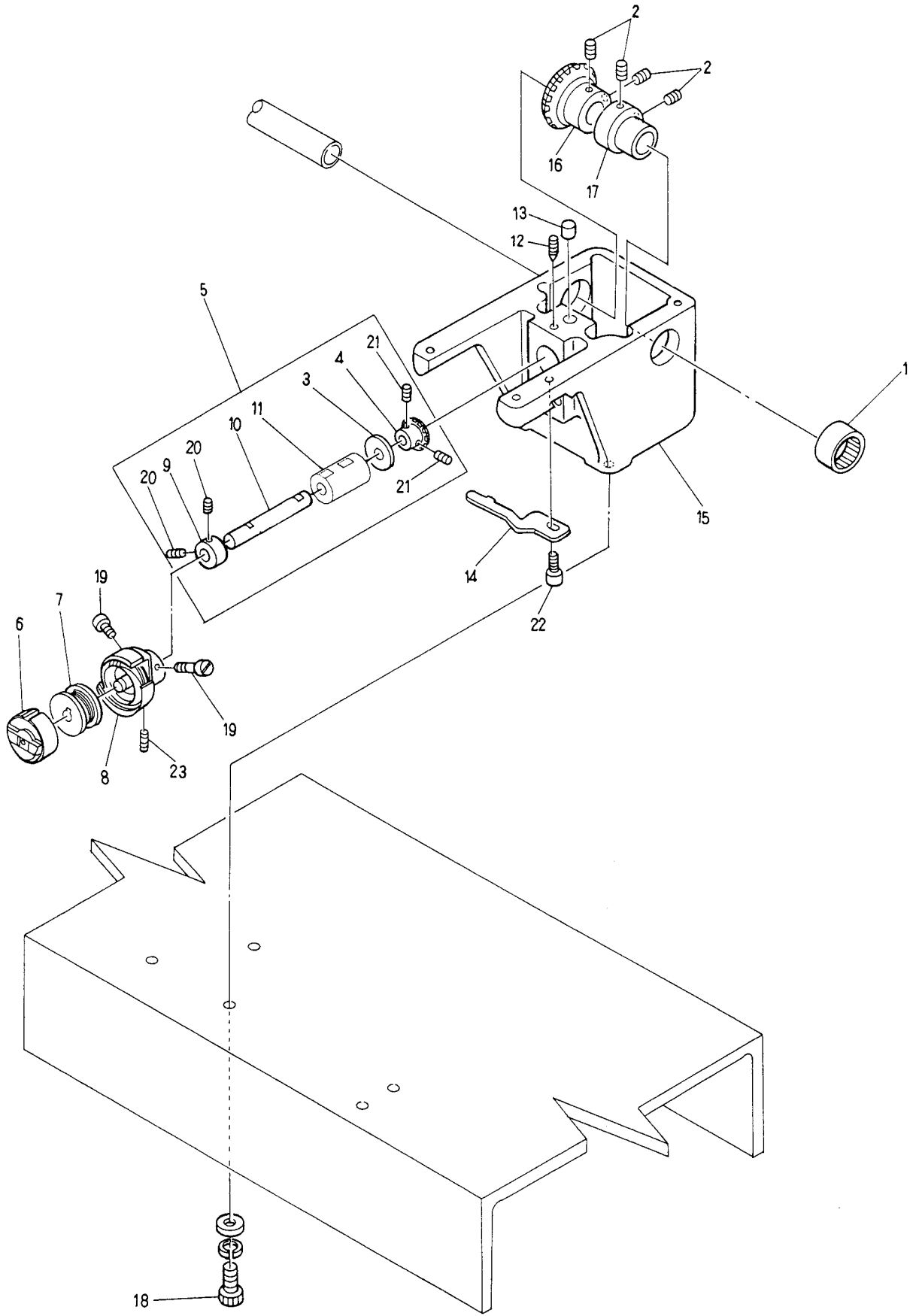

BENSH-YN/YS  
 BENRH-YN/YS



01B Head・Bed B  
ヘッド・ベッドB

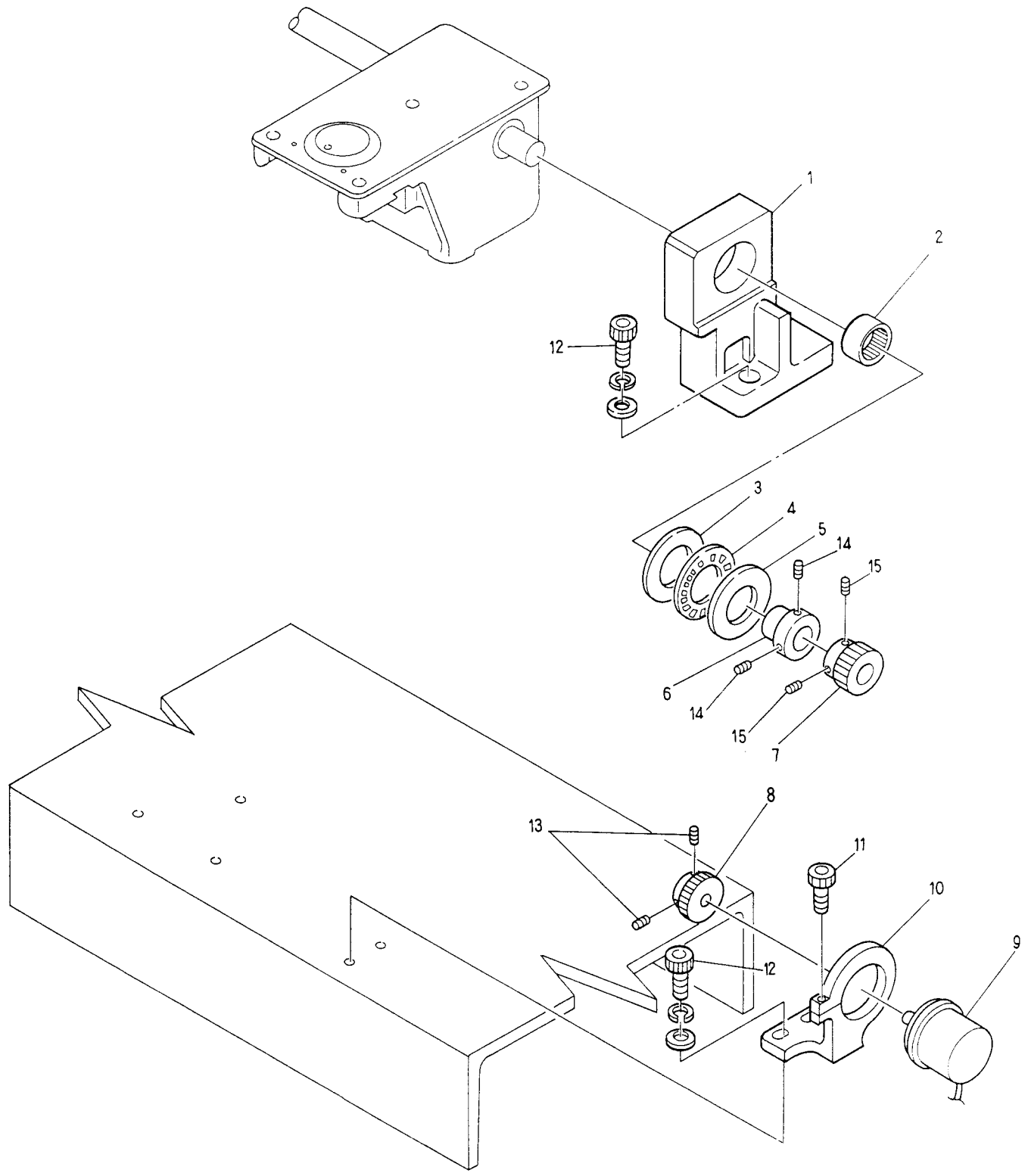

BENSH-YN/YS  
BENRH-YN/YS



02A Thread cut A  
糸切りA

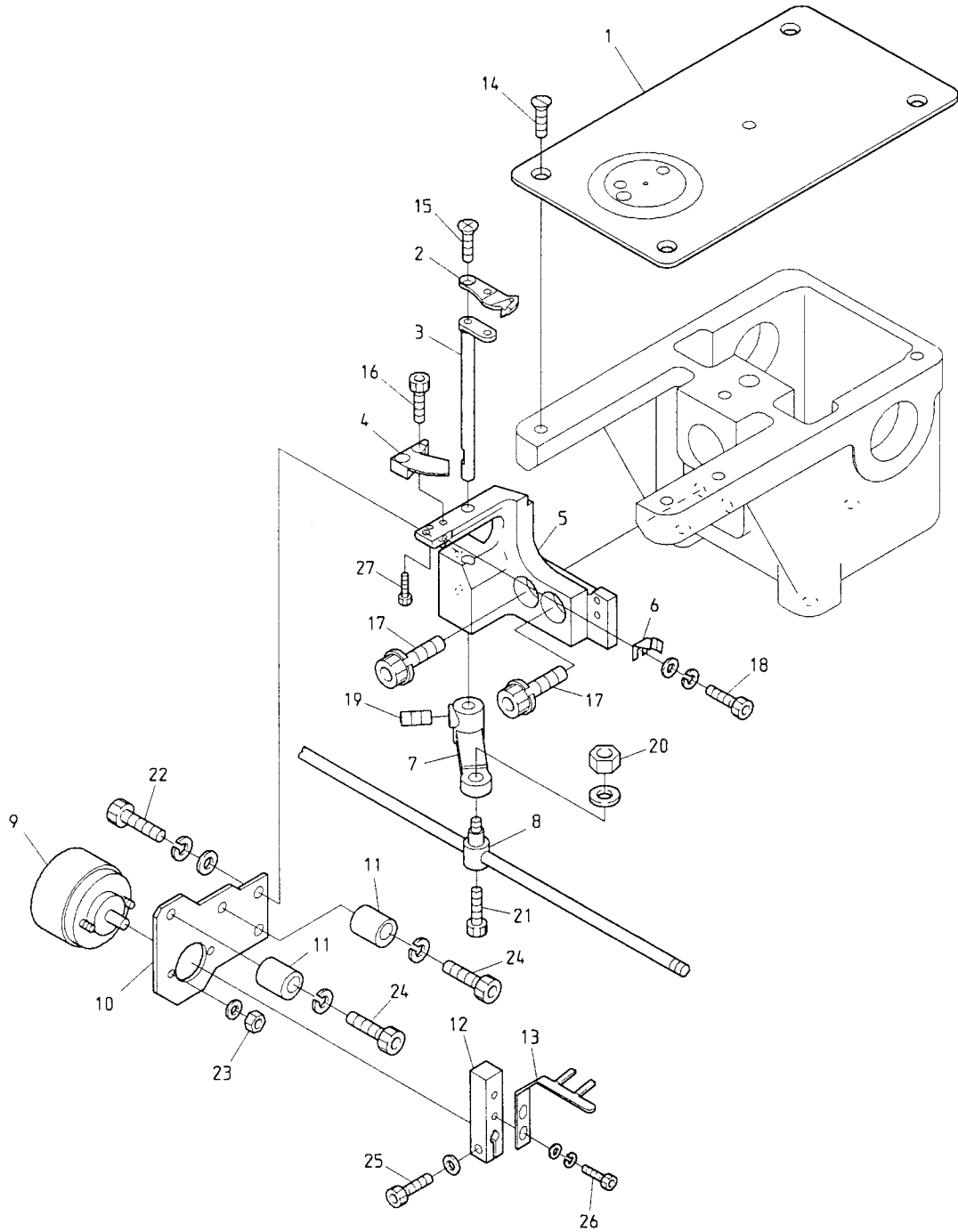

BENSH-YN/YS    BENYH-YN  
BENRH-YN/YS    BENBH-YN



02B Thread cut B  
糸切りB

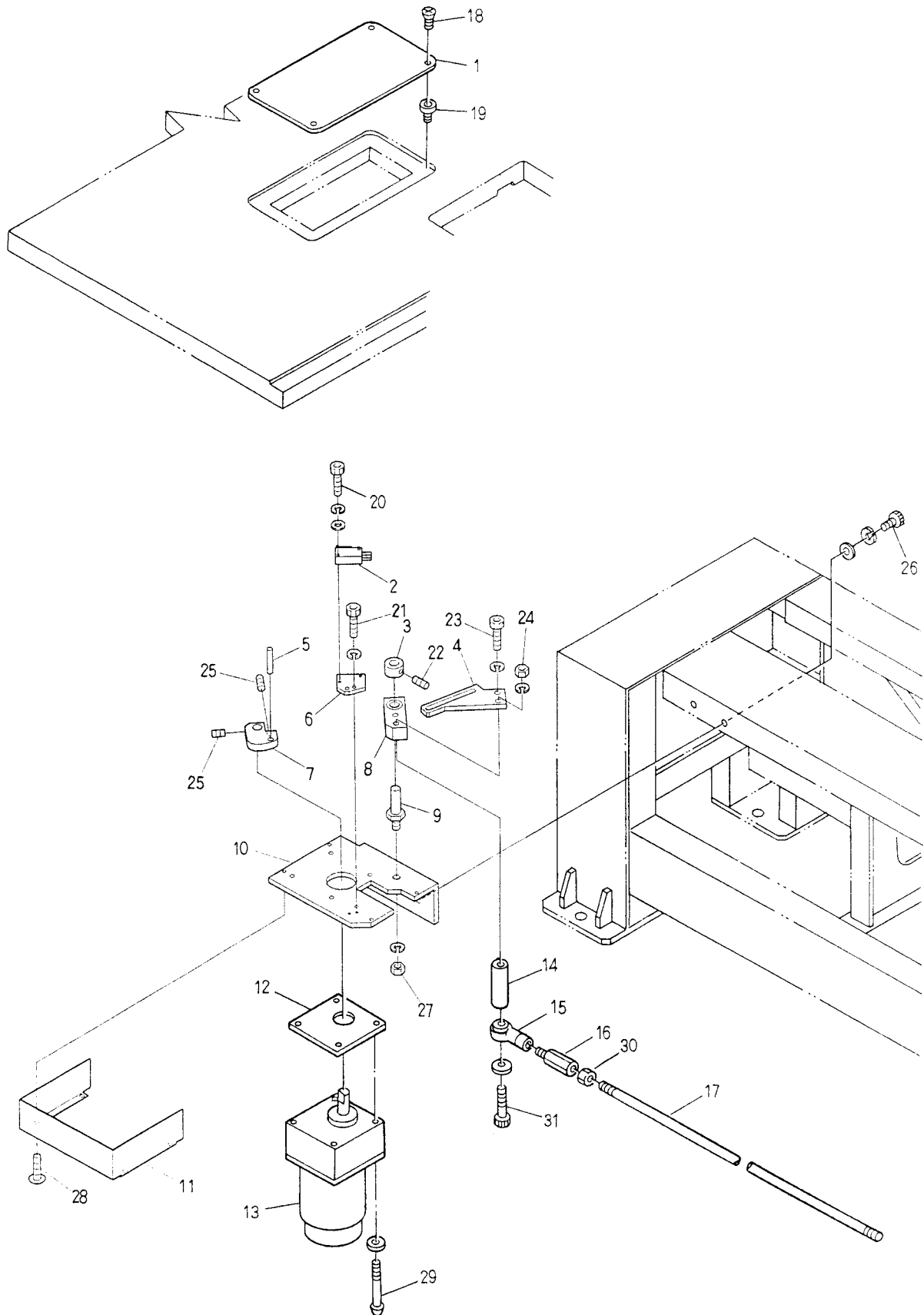

BENSH-YN/YS  
BENRH-YN/YS









02D Thread cut D  
糸切りD

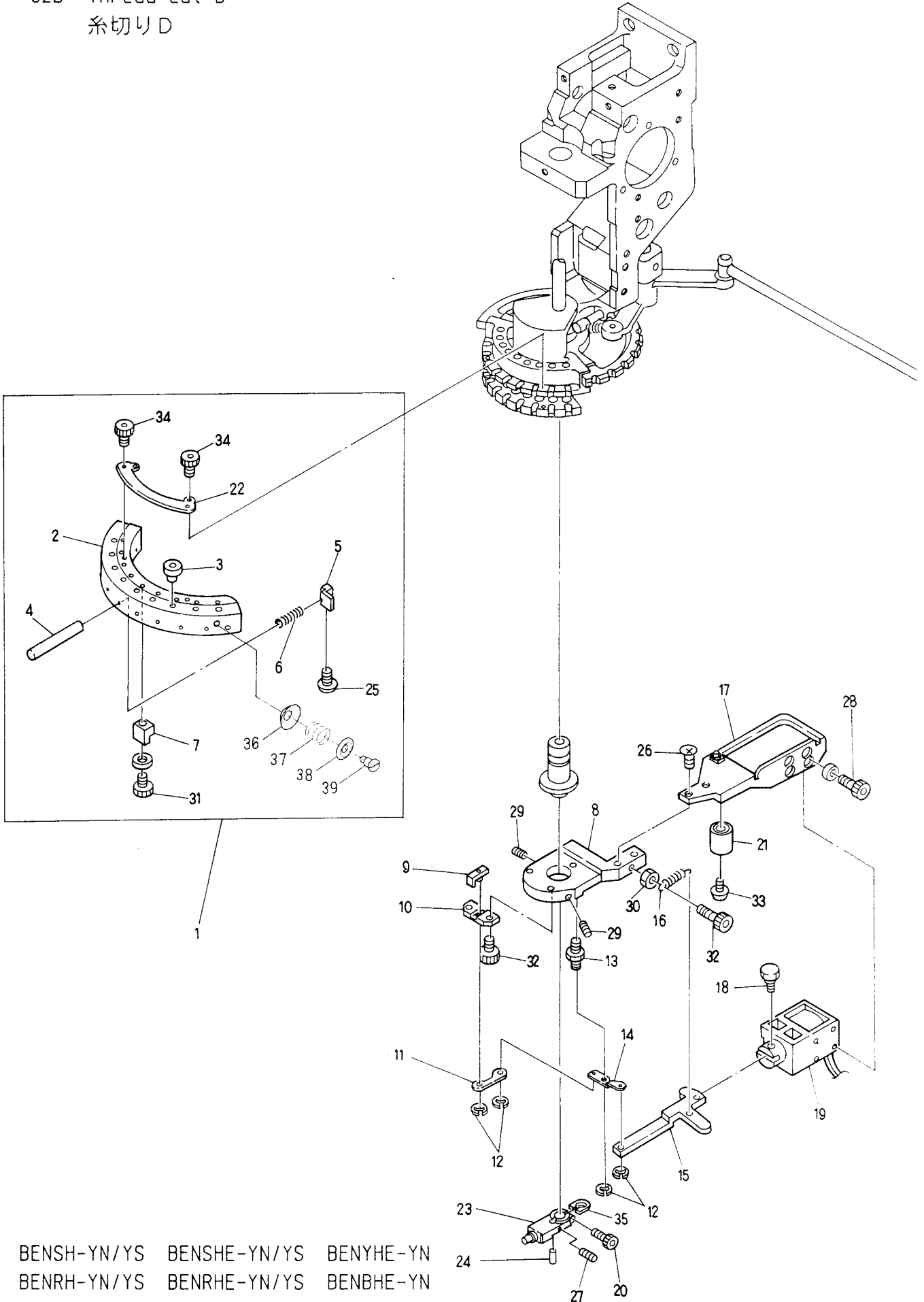

BENSH-YN/YS    BENSHE-YN/YS    BENYHE-YN  
 BENRH-YN/YS    BENRHE-YN/YS    BENBHE-YN

## 02D Thread cut D

(H=Head Q'TY)

## 糸切りD

(H=頭数)

ITEM	LIST No.	DESCRIPTION	部品名	Q'TY	NOTE
1	HT270030	Thread support apron a'ssy(YN)	糸保持エプロン a'ssy(YN)	H×1	
2	HT270001	Thread support apron(YN)	糸保持エプロン(YN)	H×1	
3	KF230582	Thread way guide (Thread support apron)	糸道ガイド (糸保持エプロン用)	H×9	
4	HT270040	Thread support shaft	糸保持軸	H×9	
5	HT270021	Thread support clamp	糸保持クランプ	H×9	
6	KC270271	Support spring	保持バネ	H×9	
7	KC270292	Thread support block	糸保持ブロック	H×9	
8	KL270000	Fixing base	取付ベース	H×1	
9	HT270120	Thread support slider	糸保持スライダー	H×1	
10	HT270100	Slide base	スライドベース	H×1	
11	HT270080	Driving plate	駆動プレート	H×1	
12	A9012056	E-Ring φ3	E型止め輪 φ3	H×4	
13	KL270040	Lever rotary shaft	レバー回転軸	H×1	
14	HT270090	Solenoid lever	ソレノイドレバー	H×1	
15	KL270060	Lever connecting plate	レバー連結プレート	H×1	
16	KL270520	Return spring	リターンスプリング	H×1	
17	KL270070	Solenoid stay	ソレノイドステー	H×1	
18	KC270101	Solenoid pin	ソレノイドピン	H×1	
19	A9056013	Keep solenoid(TDS-K10SL)	キーソレノイド(TDS-K10SL)	H×1	
20	HT270640	Driving shaft fixing clamp bolt	駆動軸固定締めボルト	H×1	
21	KN272400	Stopper eccentric	ストッパーエキセン	H×1	
22	HT270010	Thread support apron fixing stay	糸保持エプロン取付ステー	H×1	
23	HT230361	Driving shaft fixing plate	駆動軸固定プレート	H×1	
24	HT270350	Thread hook disk fixing pin	糸掛固定ピン	H×1	
25	HT270062	Set screw for thread support clamp M3×4	糸保持クランプ止めネジ M3×4	H×9	
26		Truss disk screw M4×8	十字穴付皿小ネジ M4×8		
27		Set screw M3×5	セットネジ M3×5		
28		Hex. socket bolt M3×6	六角穴付ボルト M3×6		
29		Hex. socket set screw M4×8	六角穴付止めネジ M4×8		
30		Hex. nut M4	六角ナット M4		
31		Hex. socket bolt M3×10	六角穴付ボルト M3×10		
32		Hex. socket bolt M4×8	六角穴付ボルト M4×8		
33		Truss screw M4×16	十字穴付トラス小ネジ M4×16		
34		Hex. socket bolt(Plating) M3×6	六角穴付ボルト(メッキ) M3×6		
35	HT230830	Washer for driving shaft fixing plate	駆動軸固定プレート用ワッシャー	H×1	
36	KF250220	Thread hook disk	糸カケ皿	H×2	
37	KF250241	Thread hook support spring	糸止バネ	H×2	
38	KF250231	Thread hook pressure spring	糸カケバネ押エ	H×2	
39	KF250250	Thread hook shaft screw	糸止メネジ	H×2	

03A Take up lever A  
 天秤 A

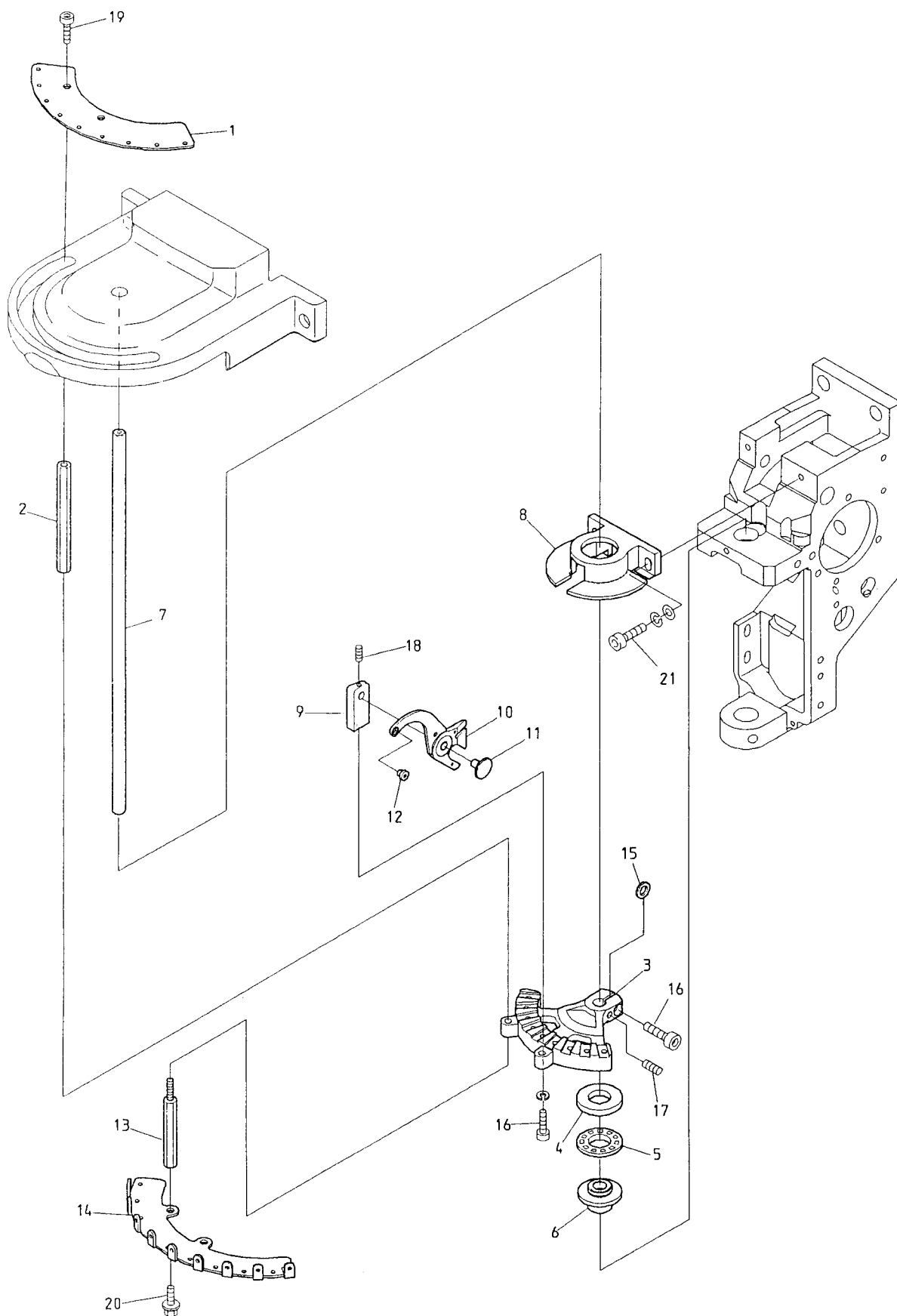

BENSH-YN/YS    BENYH-YN    BENSHE-YN/YS    BENYHE-YN  
 BENRH-YN/YS    BENBH-YN    BENRHE-YN/YS    BENBHE-YN



03B Take up lever B  
 天秤B

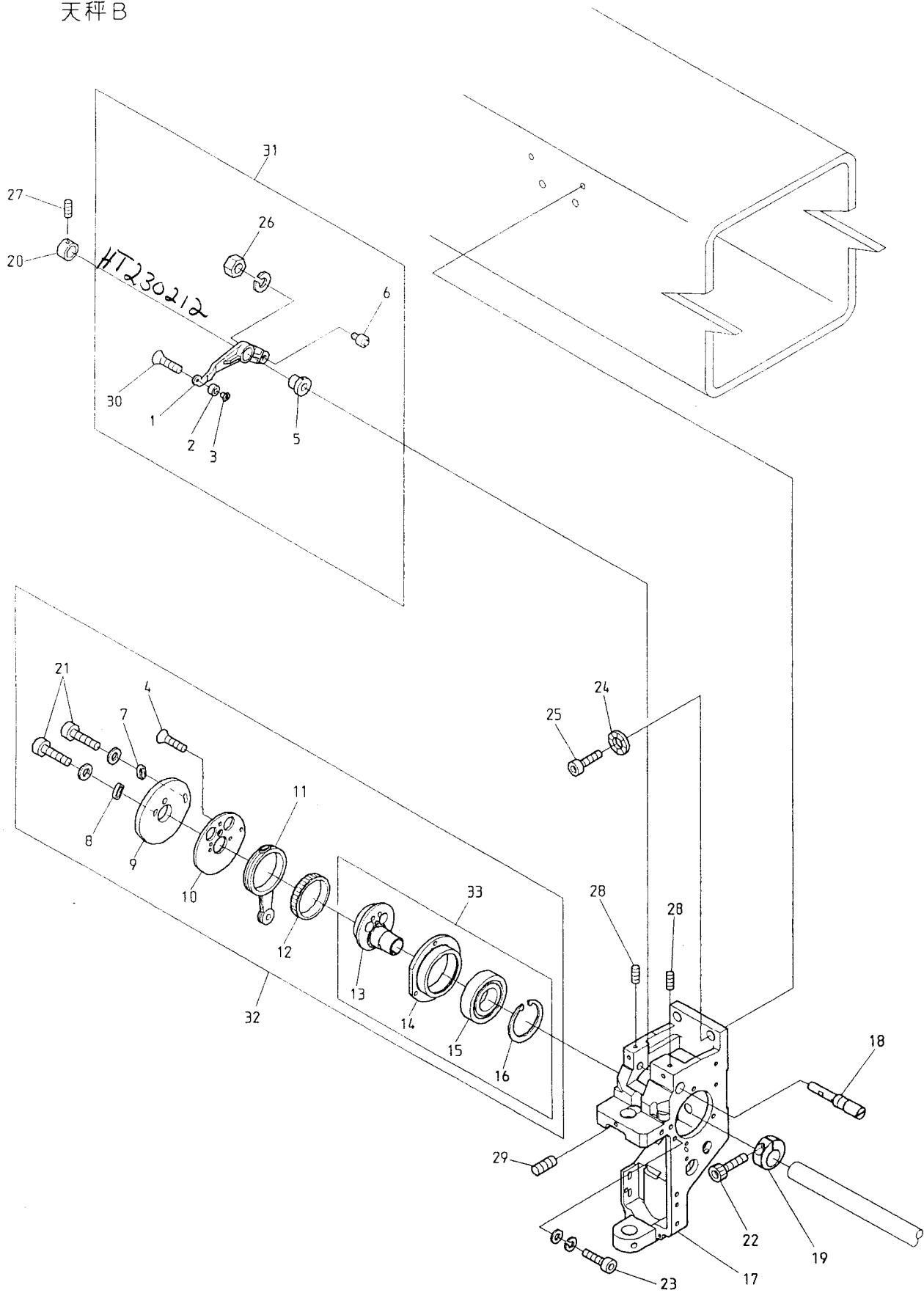

BENSH-YN/YS    BENSHE-YN/YS    BENYHE-YN  
 BENRH-YN/YS    BENRHE-YN/YS    BENBHE-YN





04A Needle bar A  
針棒A

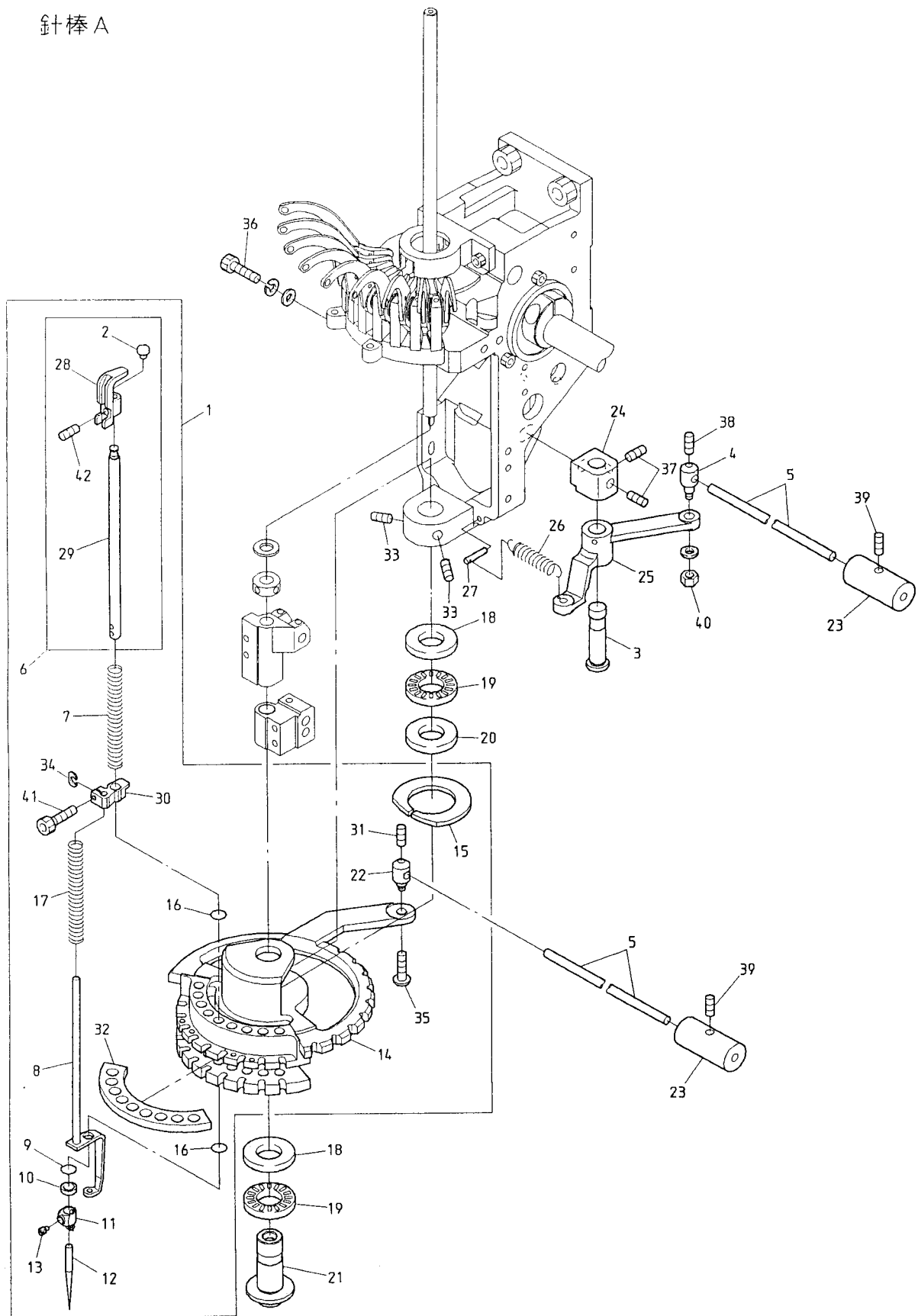

BENSH-YN/YS    BENYH-YN    BENSHE-YN/YS    BENYHE-YN  
 BENRH-YN/YS    BENBH-YN    BENRHE-YN/YS    BENBHE-YN

## 04A Needle bar A

(H=Head Q' TY)

## 針棒 A

(H = 頭数)

ITEM	LIST No.	DESCRIPTION	部品名	Q' TY	NOTE
1	HT230820	Turning plate a'ssy	回転板 a'ssy	H×1	
2	HT230130	Needle bar cap	針棒キャップ	H×9	
3	HB230190	Lock lever shaft	ロックレバーシャフト	H×1	
4	KF230640	Lock connecting bar clamp	ロック連結棒クランプ	H×1	
5	KC330410	Lock connecting rod(L=2000)	ロック連結ロッド(L=2000)	6	
6	HT230810	Needle bar a'ssy	針棒 a'ssy	H×9	
7	HT230251	Needle bar spring(Upper)	針棒バネ(上)	H×9	
8	HT230143	Pressure foot(YN with ditch)	布押え(YN溝付)	H×9	
9	KF230910	O-Ring(Small) P-6	Oリング(小) P-6	H×9	
10	HT230120	Washer 2.4	ジュラコンワッシャー 2.4	H×9	
11	HT230670	Needle clamp(With hook)	針止め(フック付)	H×9	
12	FN070011SNY	Needle(DBXK5-NY11S)	針(DBXK5-NY11S)	H×9	
13	KF230240	Needle clamp screw(SM9/64)	針止めネジ(SM9/64)	H×9	
14	HT230570	Turning plate	回転板	H×1	
15	HT230690	Turning plate felt(Upper)	回転板フェルト(上)	H×1	
16	A9014055	O-Ring(IAS-7) S-7	Oリング(IAS-7) S-7	H×1	
17	HT230063	Needle bar spring(Under)	針棒バネ(下)	H×18	
18	A9011023	Thrust bearing outer(GS1528)	スラストベアリング外輪(GS1528)	H×2	
19	A9011021	Thrust bearing(NTB-1528)	スラストベアリング(NTB-1528)	H×2	
20	A9011022	Thrust washer(AS-1528)	スラストワッシャー(AS-1528)	H×1	
21	HT230550	Driving shaft lower metal	駆動軸下メタル	H×1	
22	HT230180	Turning plate joint pin	回転板ジョイントピン	H×1	
23	KF330180	Lock bar hand grip	糸操作グリップ	4	
24	HB230180	Lock lever bracket	ロックレバーブラケット	H×1	
25	KL230180	Lock lever	ロックレバー	H×1	
26	KF230661	Lock lever spring	ロックレバースプリング	H×1	
27	KF230670	Lock lever spring pin	ロックレバースプリングピン	H×1	
28	HT230151	Needle bar guide	針棒ガイド	H×1	
29	HT230041	Needle bar	針棒	H×1	
30	HT230330	Cloth winder stop latch set clamp	布押えセットクランプ	H×1	
31		Hex. socket set screw M4×4	六角穴付止めネジ M4×4		
32	HT230111	Turning plate felt	回転板フェルト	H×1	
33	A9012053	Hex. socket set screw(With steel ball) M6×0.7×8	六角穴付止めネジ(鋼球付) M6×0.7×8	H×2	
34	HT230263	Washer(For set clamp)	セットクランプ用座金	H×9	
35		Hex. socket button bolt M4×5	六角穴付ボタンボルト M4×5		
36		Hex. socket bolt M8×18	六角穴付ボルト M8×18		
37		Hex. socket set screw M6×6	六角穴付止めネジ M6×6		
38		Hex. socket set screw M4×6	六角穴付止めネジ M4×6		
39		Hex. socket set screw M5×5	六角穴付止めネジ M5×5		
40		Hex. nut M1(Ⅱ)	六角ナット M1(2種)		
41		Hex. socket bolt M3×8	六角穴付ボルト M3×8		
42		Hex. socket set screw M4×4 (With adhesion)	六角穴付止めネジ M4×4 (接着剤付)		

04B Needle bar B  
針棒B

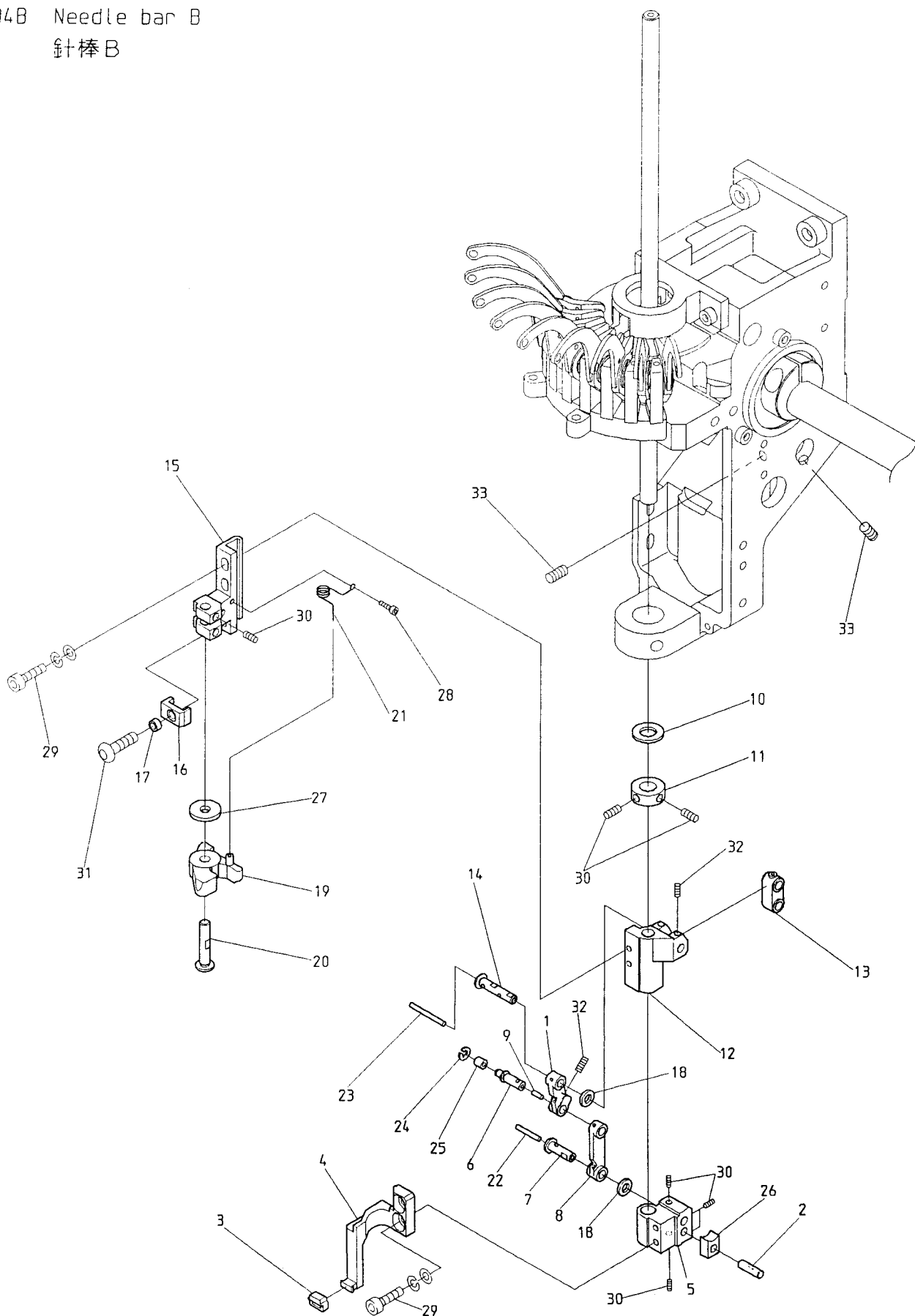

BENSH-YN/YS    BENYH-YN    BENSHE-YN/YS    BENYHE-YN  
 BENRH-YN/YS    BENBH-YN    BENRHE-YN/YS    BENBHE-YN



04C Needle bar C  
針棒C

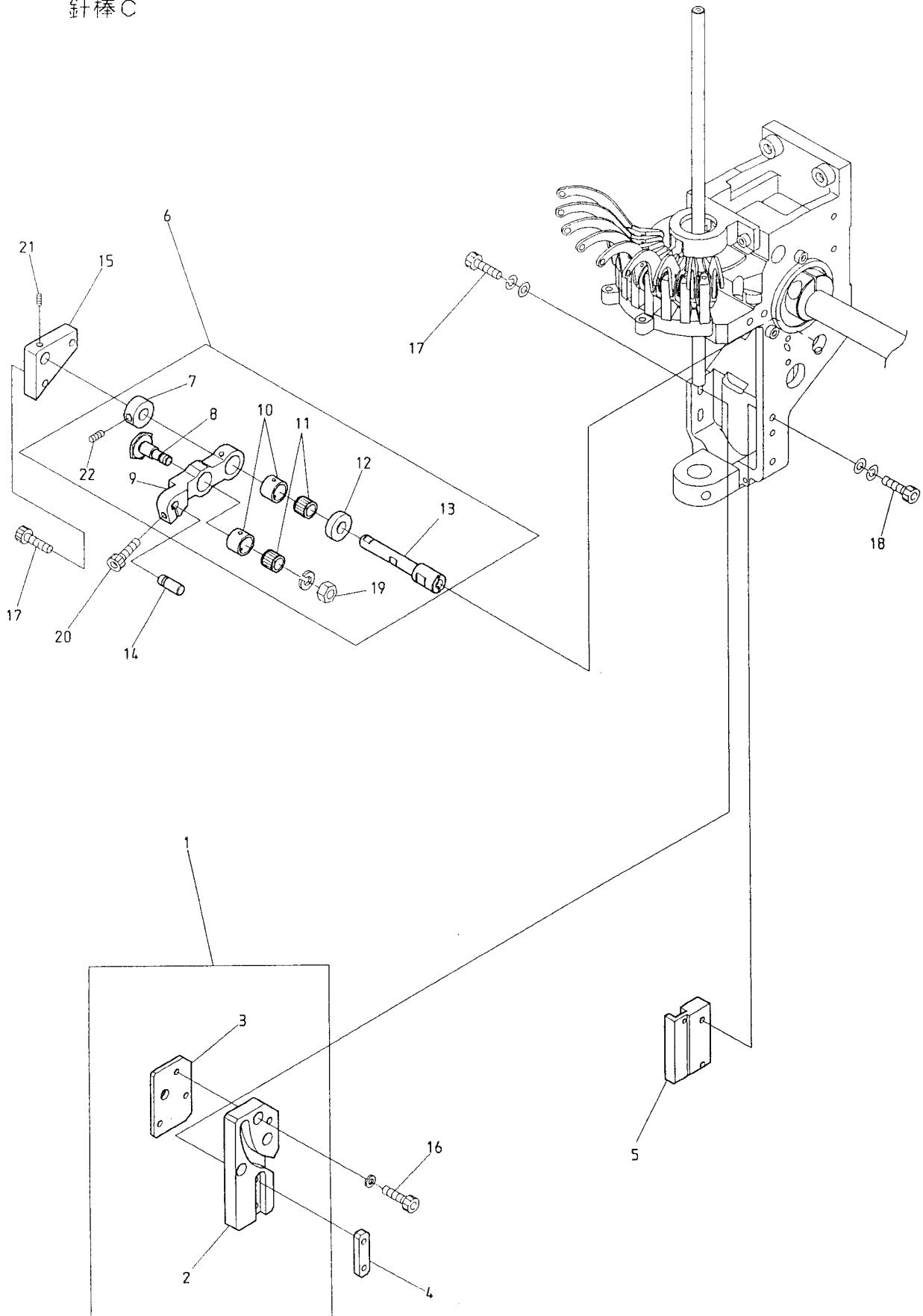

BENSH-YN/YS    BENYH-YN    BENSHE-YN/YS    BENYHE-YN  
 BENRH-YN/YS    BENBH-YN    BENRHE-YN/YS    BENBHE-YN



05 Jump  
ジャンプ

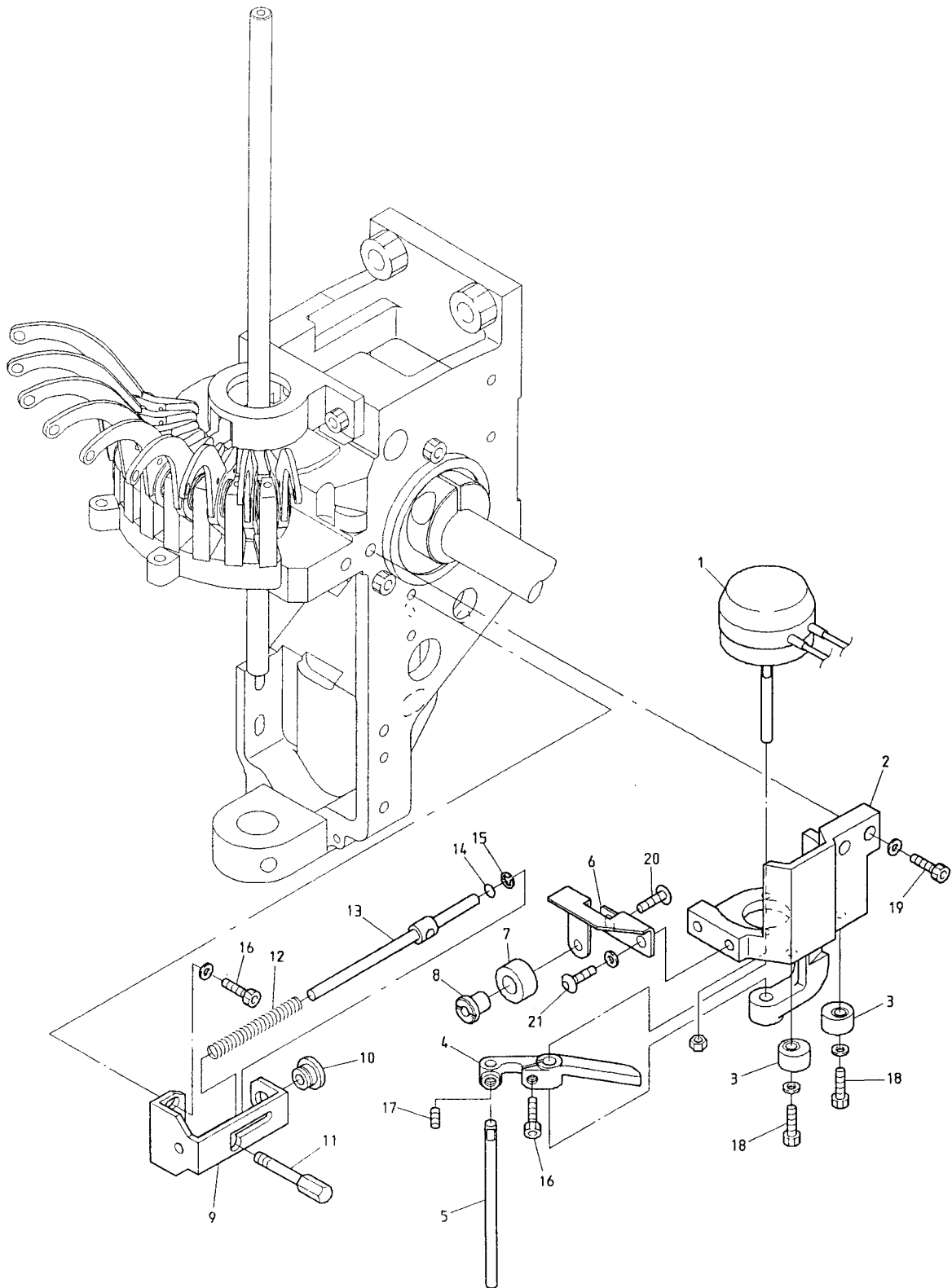

From the library of: Diamond Needle Corp

BENSH-YN/YS    BENSHE-YN/YS    BENYHE-YN  
 BENRH-YN/YS    BENRHE-YN/YS    BENBHE-YN





06A-1 Thread guide A (Standard)(YN)  
 糸道A (標準) (YN)

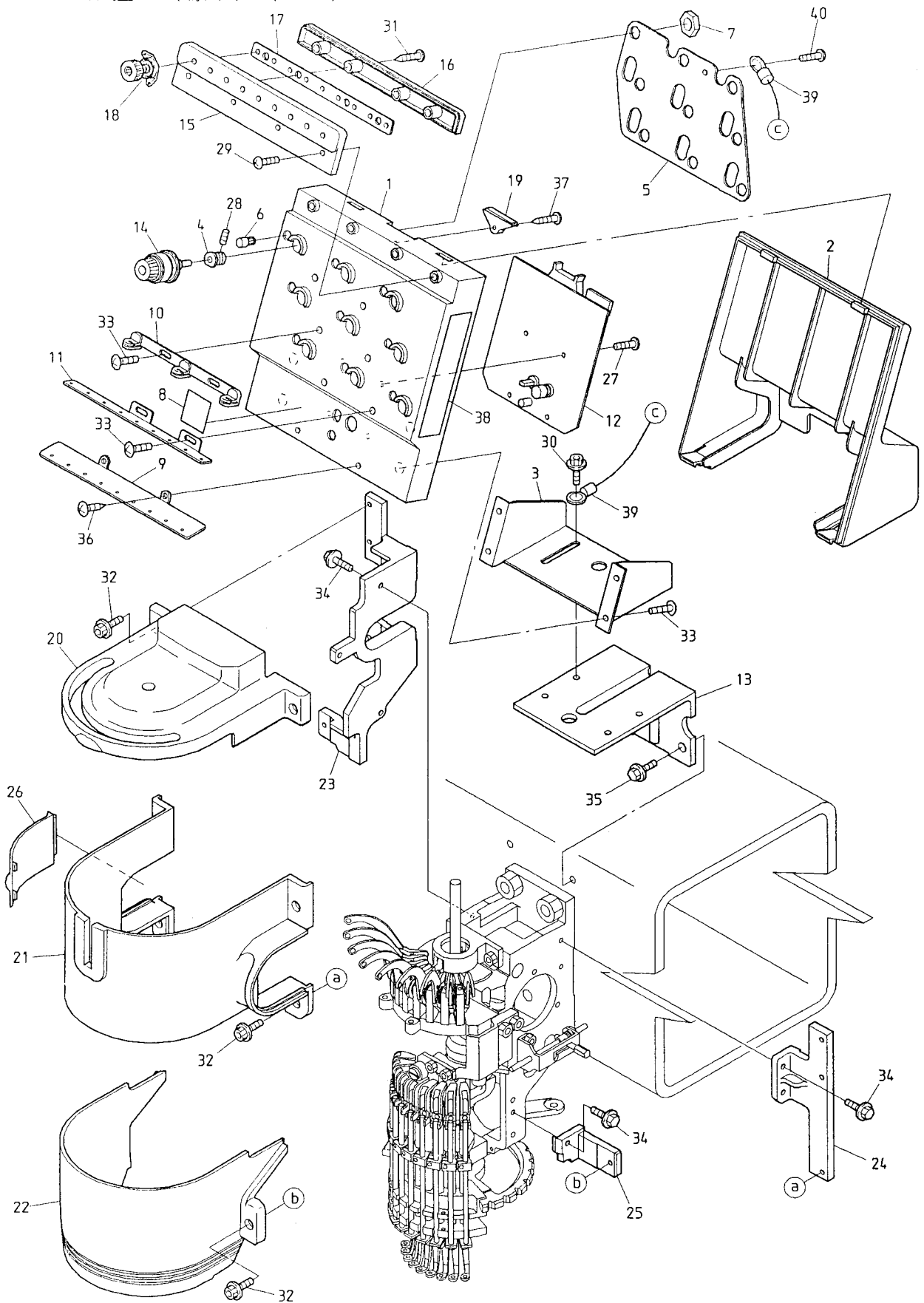

BENSH-YN/YS    BENSHE-YN/YS    BENYHE-YN  
 BENRH-YN/YS    BENRHE-YN/YS    BENBHE-YN



06A-2 Thread guide A (Standard)(YS)  
糸道A(標準)(YS)

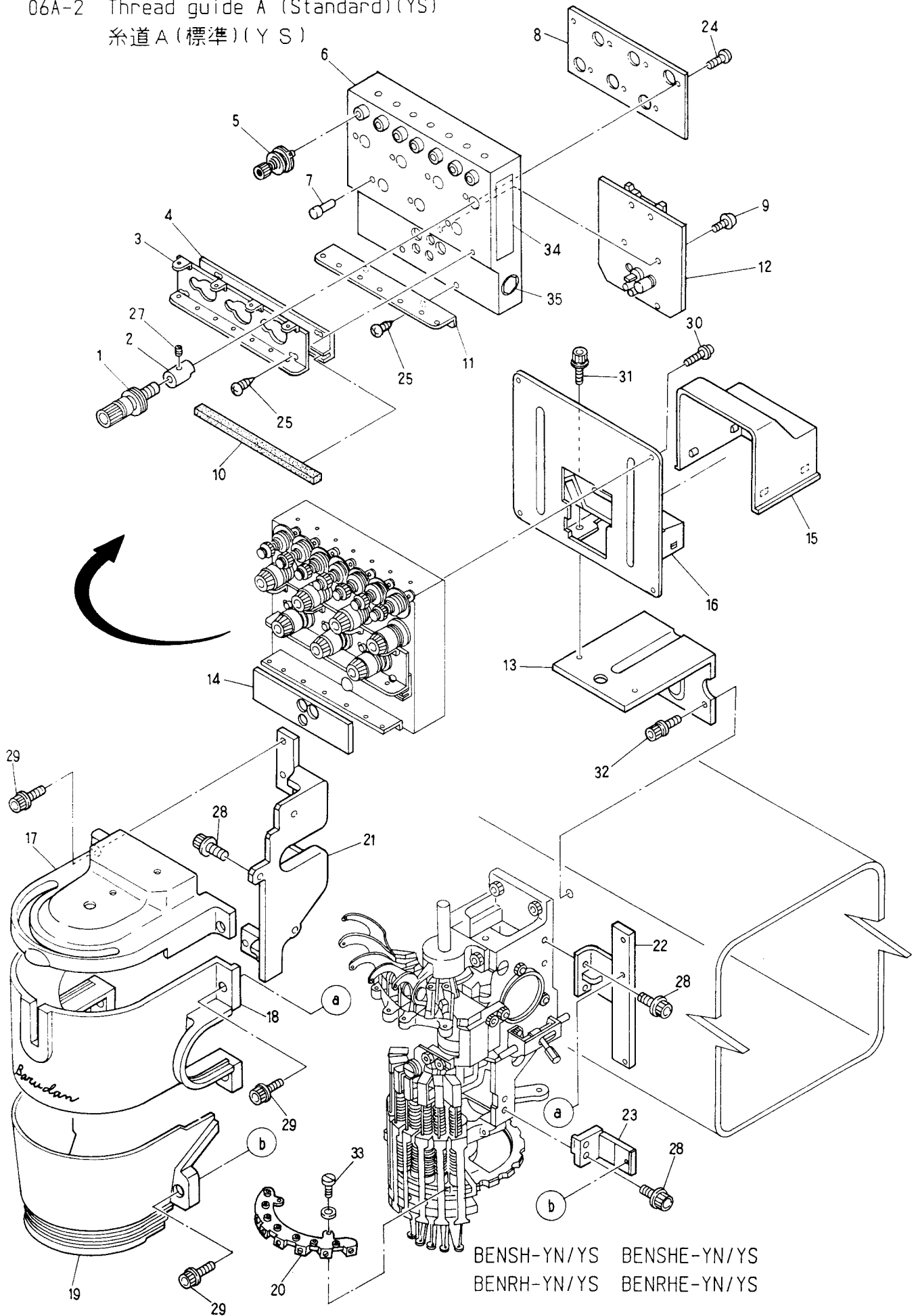

BENSH-YN/YS    BENSHE-YN/YS  
BENRH-YN/YS    BENRHE-YN/YS



06B-1 Thread guide B (Standard) (YN)  
糸道B(標準)(YN)

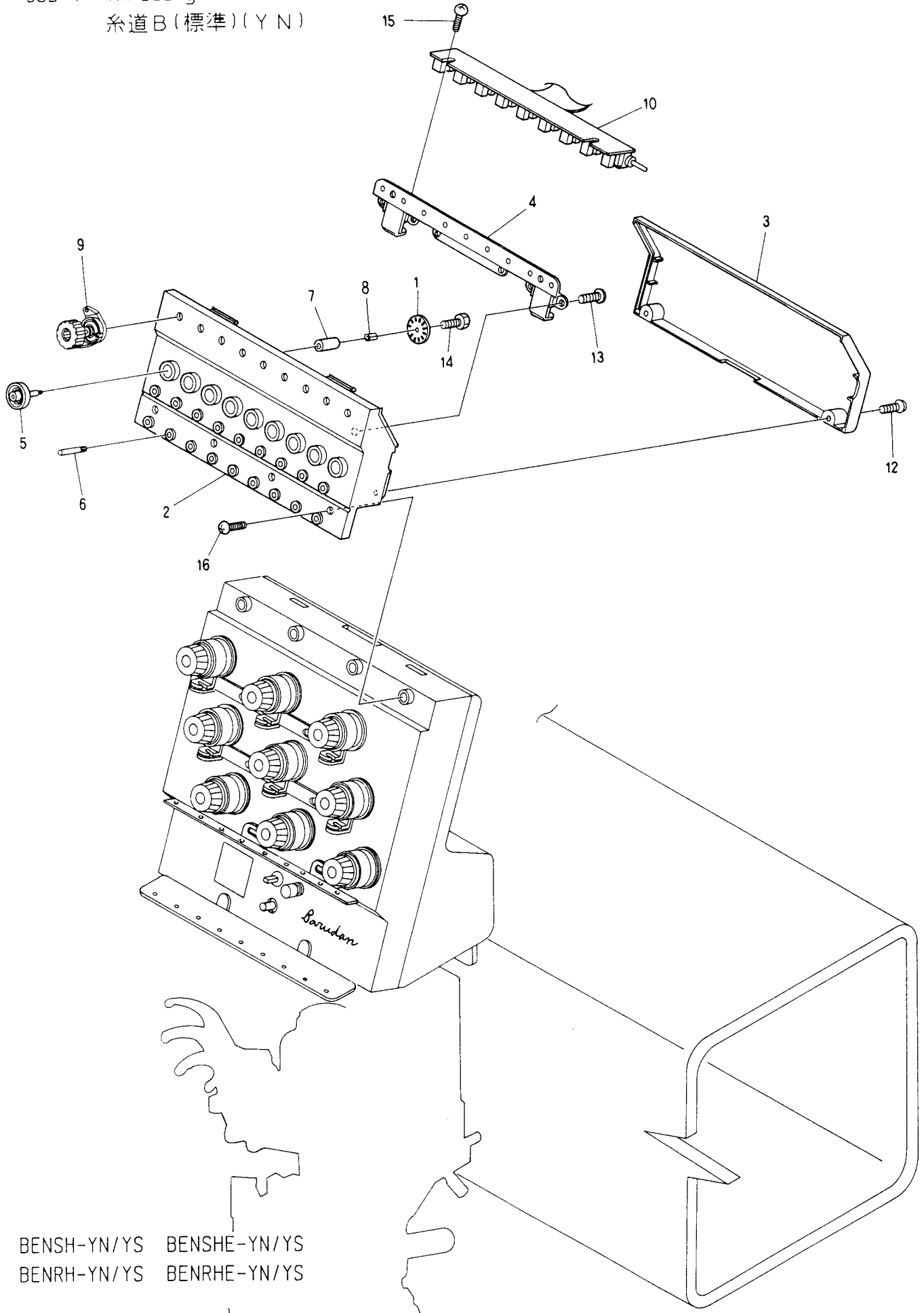

BENSH-YN/YS    BENSHE-YN/YS  
BENRH-YN/YS    BENRHE-YN/YS





C6B-2 Thread guide B (Standard)(YS)  
 糸道B(標準)(YS)

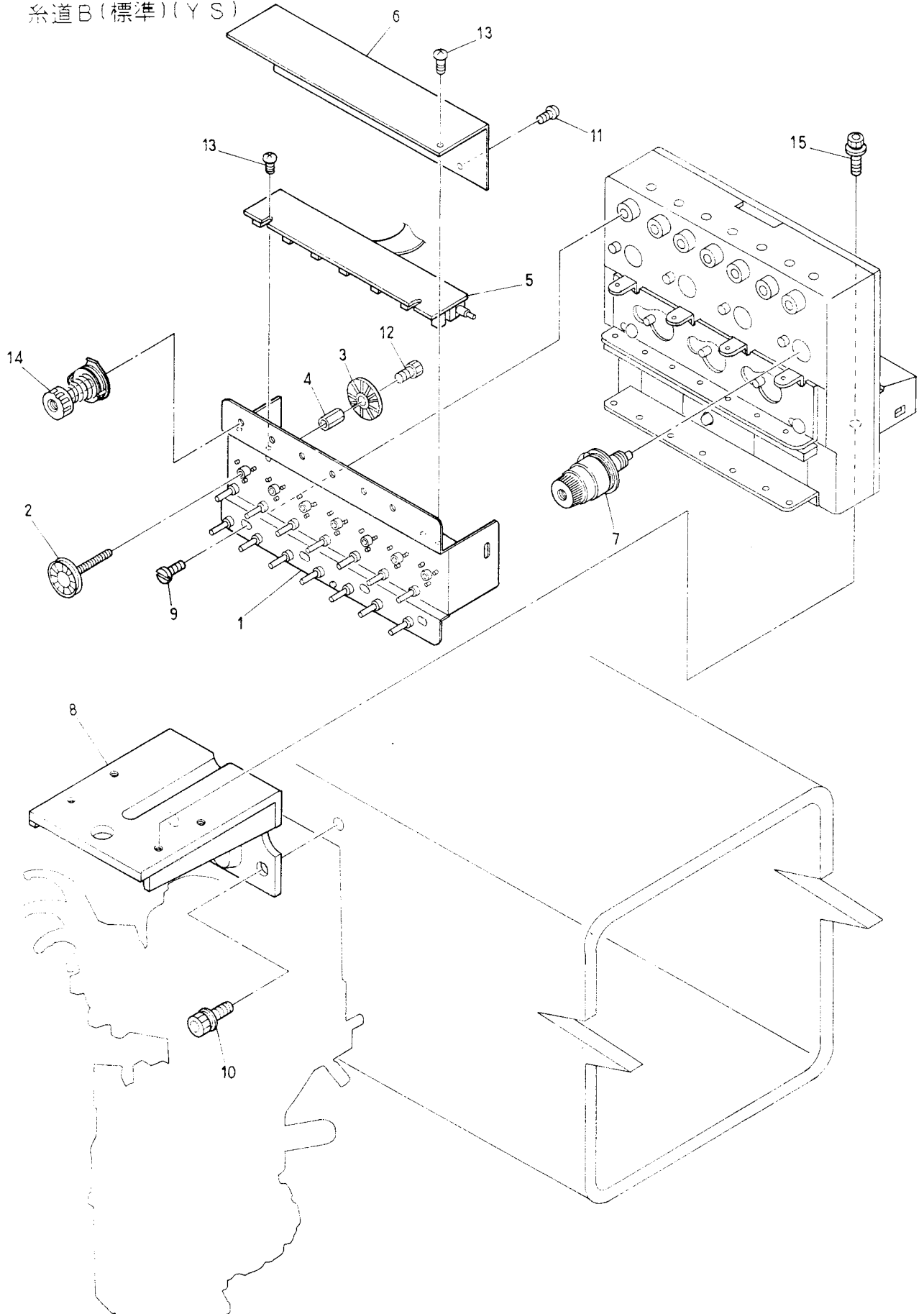

BENSH-YN/YS    BENSHE-YN/YS  
 BENRH-YN/YS    BENRHE-YN/YS





07A Color change A  
色換えA

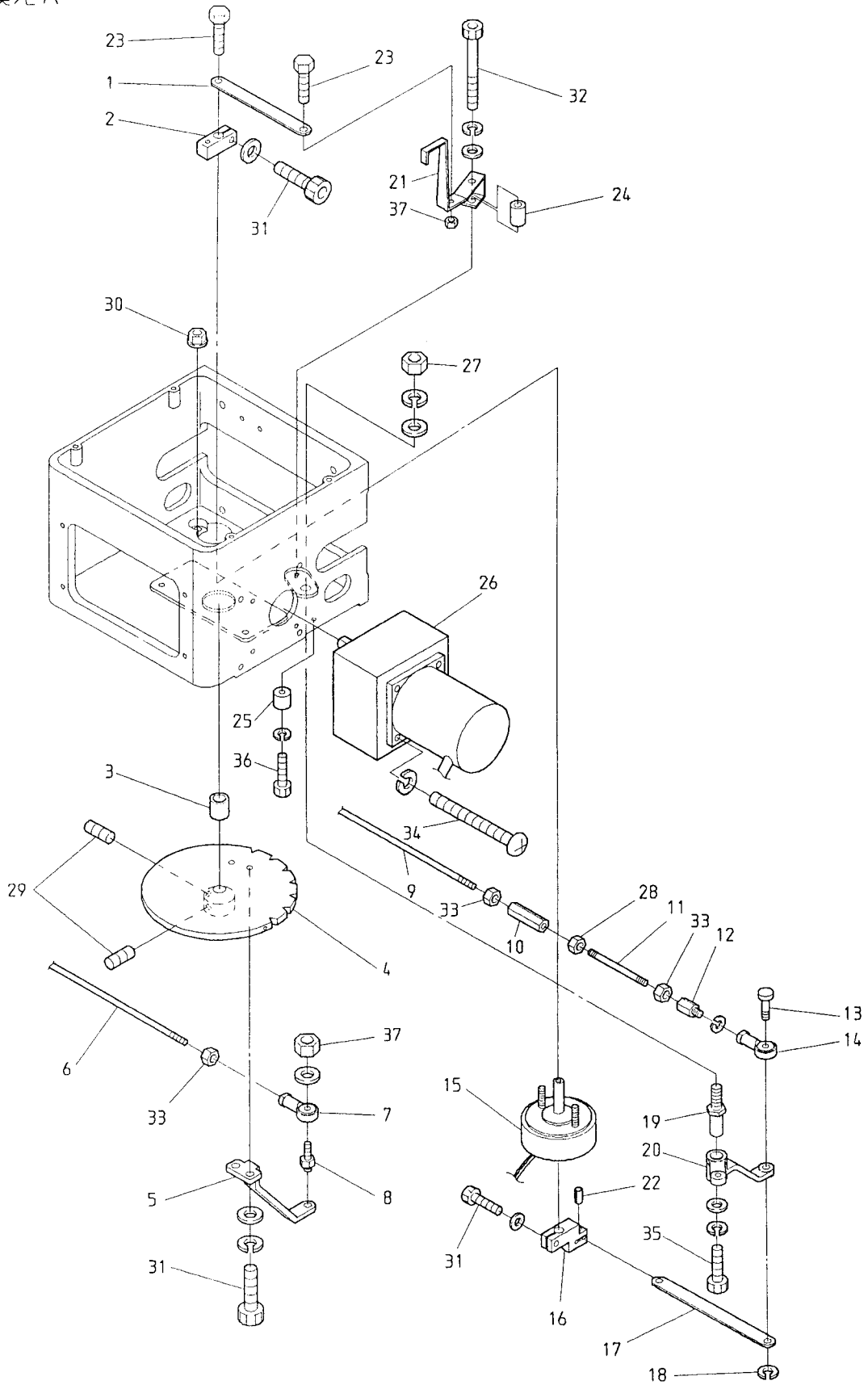

BENSH-YN/YS    BENSHE-YN/YS  
BENRH-YN/YS    BENRHE-YN/YS



07B Color change B  
色換えB

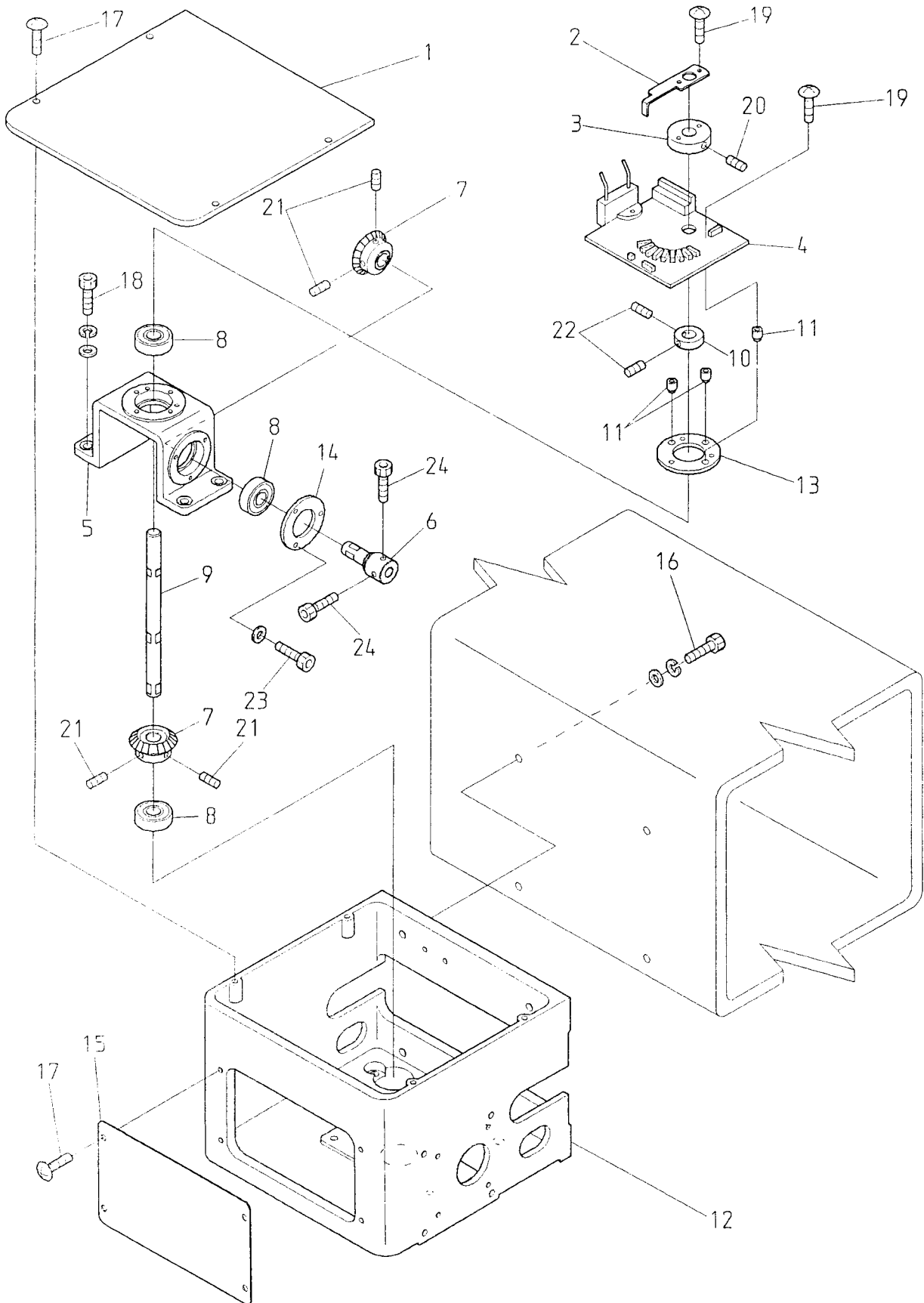

BENSH-YN/YS    BENSHE-YN/YS  
BENRH-YN/YS    BENRHE-YN/YS



08A Drive A  
駆動A

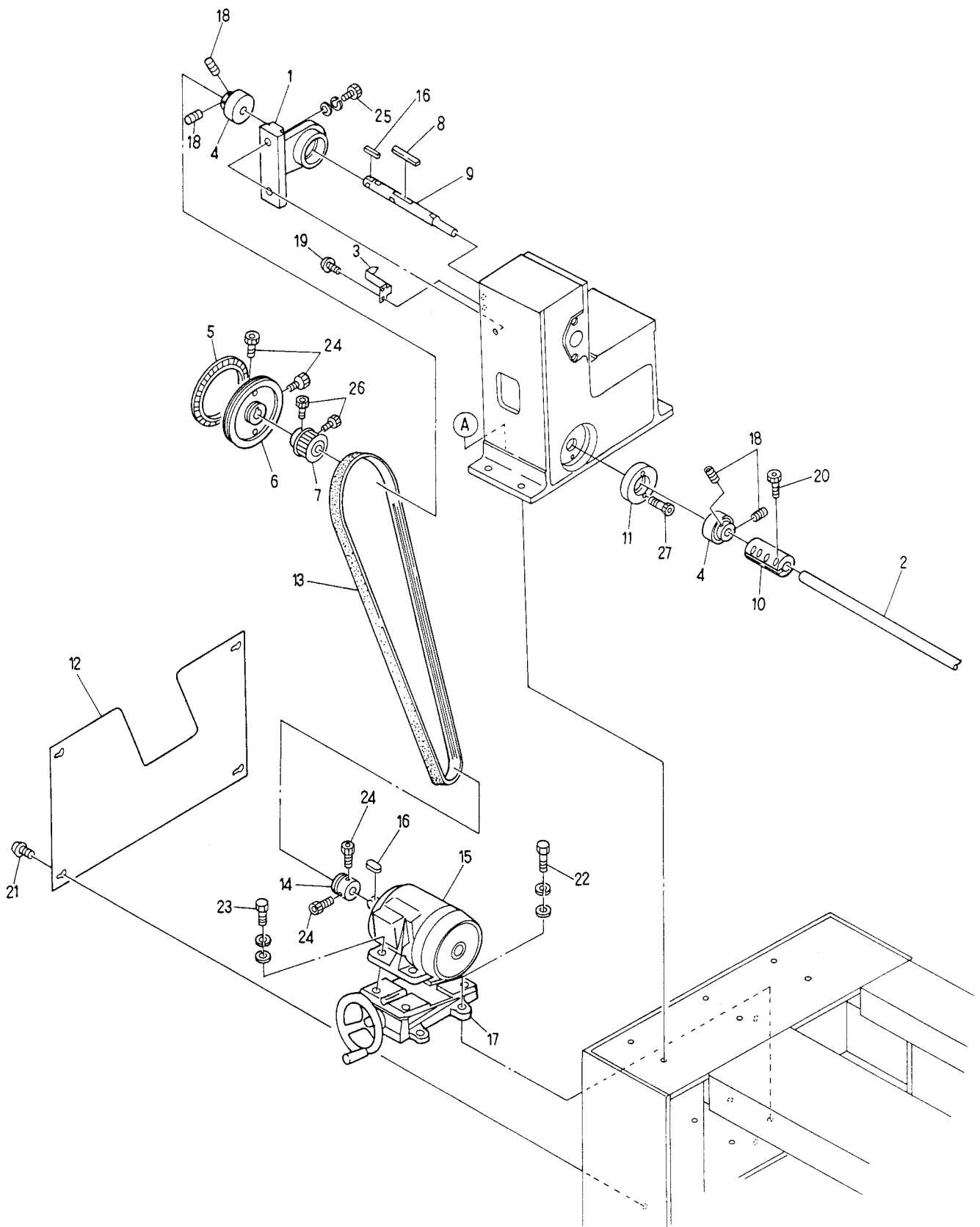

BENSH-YN/YS  
BENRH-YN/YS



08B Drive B  
駆動B

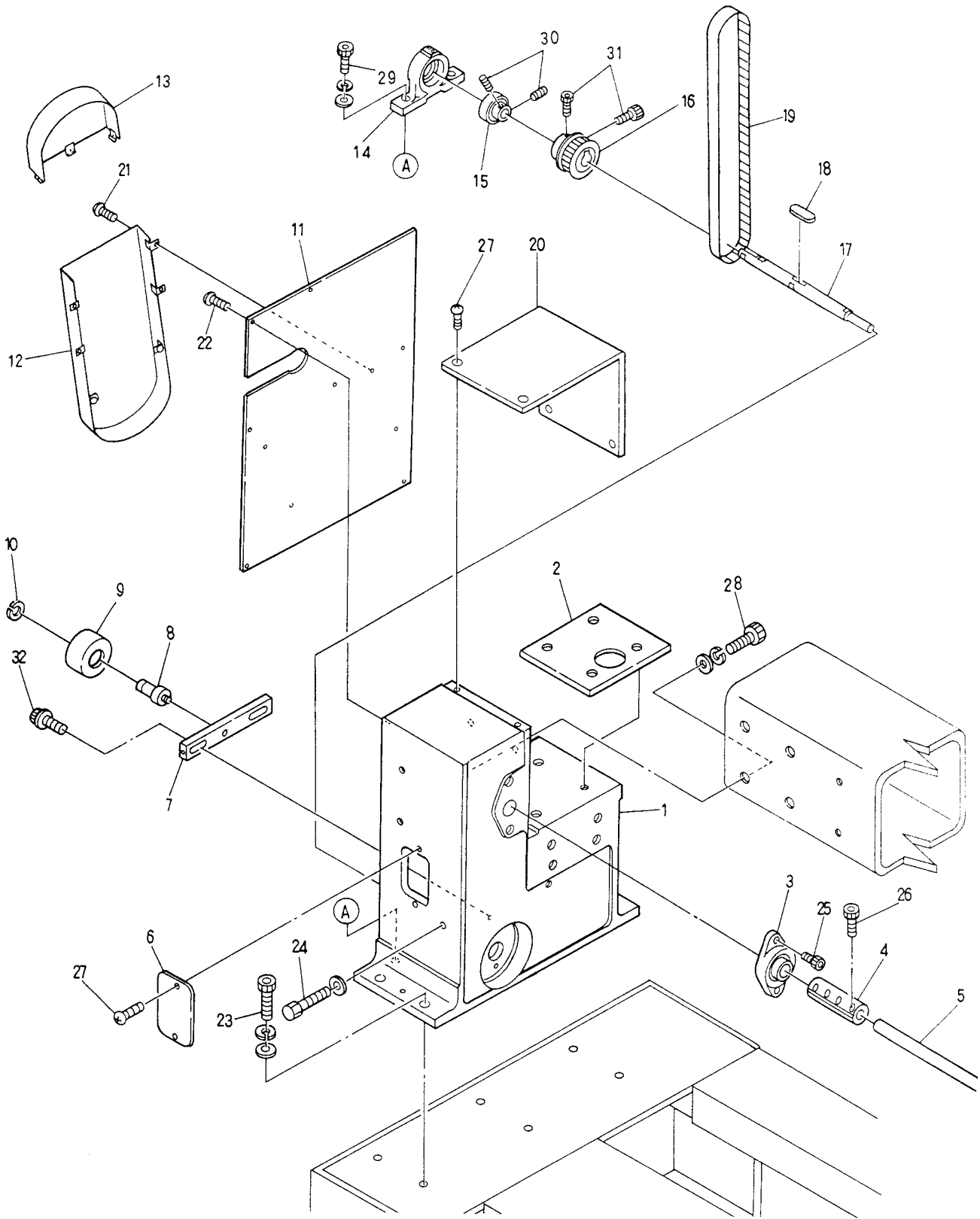

BENSH-YN/YS  
BENRH-YN/YS





10A Pantograph drive A  
枠駆動A

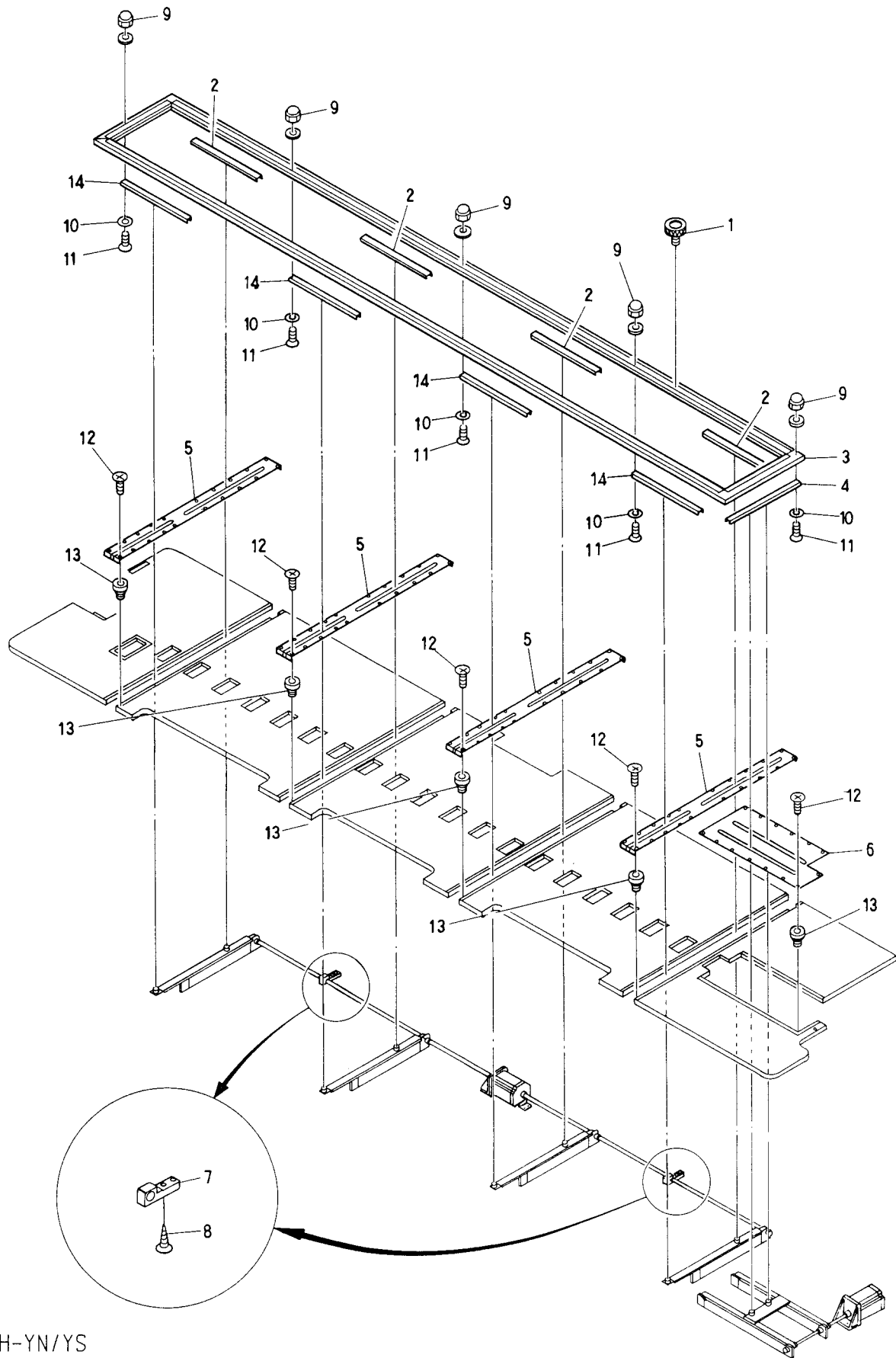

BENSH-YN/YS  
BENRH-YN/YS



10B Pantograph drive B  
 枠駆動B

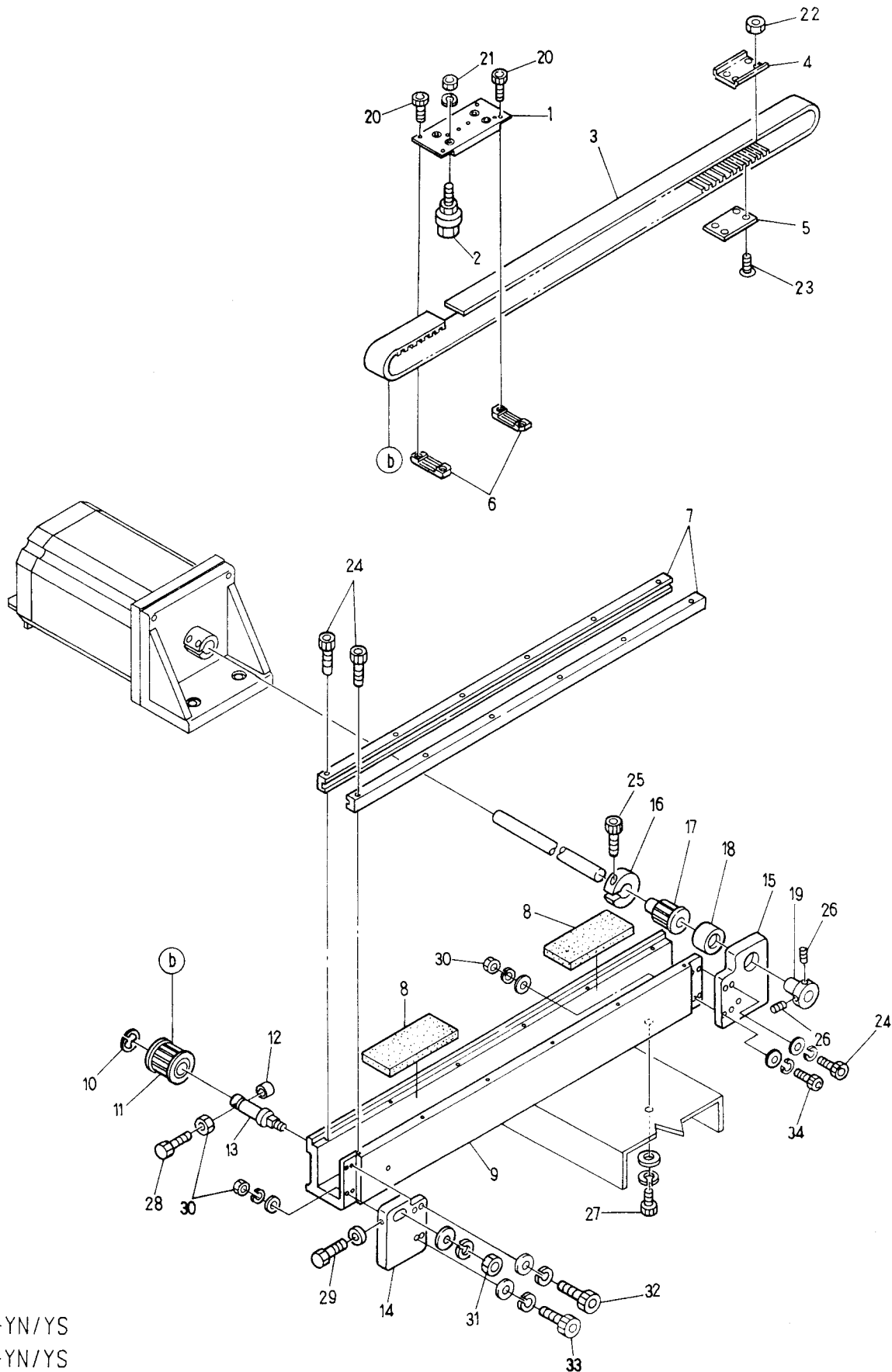

BENSH-YN/YS  
 BENRH-YN/YS

10B Pantograph drive B  
 枠駆動 B

(R=H-direction rail Q'TY)(※ Depends on machine type)

(R=H方向レール数)(※は機種によって異なる)

ITEM	LIST No	DESCRIPTION	部品名	Q'TY	NOTE
1	HP482871	H-Roller base(Rear)	Hローラーベース(後)	R×1	
2	HP482950	Roller pin a'ssy A	ローラーピン組 A	R×4	
3	A9020098	Timing belt(300S5M2000)	タイミングベルト(300S5M2000)	R×1	
	A9020178	Timing belt(300S5M2525)	タイミングベルト(300S5M2525)	3~4	H-Stroke 850 over Hストローク850以上
4	HH482031	Belt connecting plate No.1	ベルト連結金具 No.1	R×1	H-Stroke 850 over Hストローク850以上
5	HH482041	Belt connecting plate No.2	ベルト連結金具 No.2	R×1	H-Stroke 850 over Hストローク850以上
6	HP482940	Timing belt set rack(5M)	タイミングベルト押さえラック(5M)	R×2	
7	HP482910	V-Guide rail(L=1060)	V溝レール(L=1060)	R×2	
8	KN480061	Rail base felt(100×38×6)	レール土台フェルト(100×38×6)	R×2	
9	HH48209G45	H-Guide rail base(Stroke 450)	H案内レール土台(ストローク450)	R×1	※
10	A9012052	E-Ring φ10	E型止め輪 φ10	R×1	
11	HV480050	Pantograph driving pulley(Front) S5M	枠駆動プーリー(前) S5M	R×1	
12	HH482110	Pulley shaft bolt cap	プーリーシャフトボルトキャップ	R×1	
13	HH481991	Timing pully shaft	従動プーリーシャフト	R×1	
14	HH482000	H-Guide front pulley bracket	H案内前プーリーブラケット	R×1	
15	HV480030	H-Guide rear pulley bracket	H案内後プーリーブラケット	R×1	
16	HH481980	Clamping φ19	φ19 割りクランプ	R×1	
17	HV480040	Pantograph driving pully(Rear) S5M	枠駆動プーリー(後) S5M	R×1	
18	A9011063	Needle bearing(TLA 2016)	ニードルベアリング(TLA 2016)	R×1	
19	HH481970	Pulse motor connecting shaft collar	パルスモーター連結シャフトカラー	R×1	
20		Hex. socket bolt M3×6	六角穴付ボルト M3×6		
21		Hex. nut M5	六角ナット M5		
22		Hex. nut M3	六角ナット M3		
23		Truss screw M3×10	十字穴付皿ネジ M3×10		
24		Hex. socket bolt M4×15	六角穴付ボルト M4×15		
25		Hex. socket bolt M5×18	六角穴付ボルト M5×18		
26		Hex. socket set screw M5×8	六角穴付止めネジ M5×8		
27		Hex. socket bolt M8×25	六角穴付ボルト M8×25		
28		Hex. bolt M4×35	六角ボルト M4×35		
29		Hex. bolt M4×25	六角ボルト M4×25		
30		Hex. nut M4	六角ナット M4		
31		Hex. nut M8	六角ナット M8		
32		Hex. socket bolt M4×18	六角穴付ボルト M4×18		
33		Hex. socket bolt M4×22	六角穴付ボルト M4×22		
34		Hex. socket bolt M4×20	六角穴付ボルト M4×20		

10C Pantograph drive C  
 枱驅動C

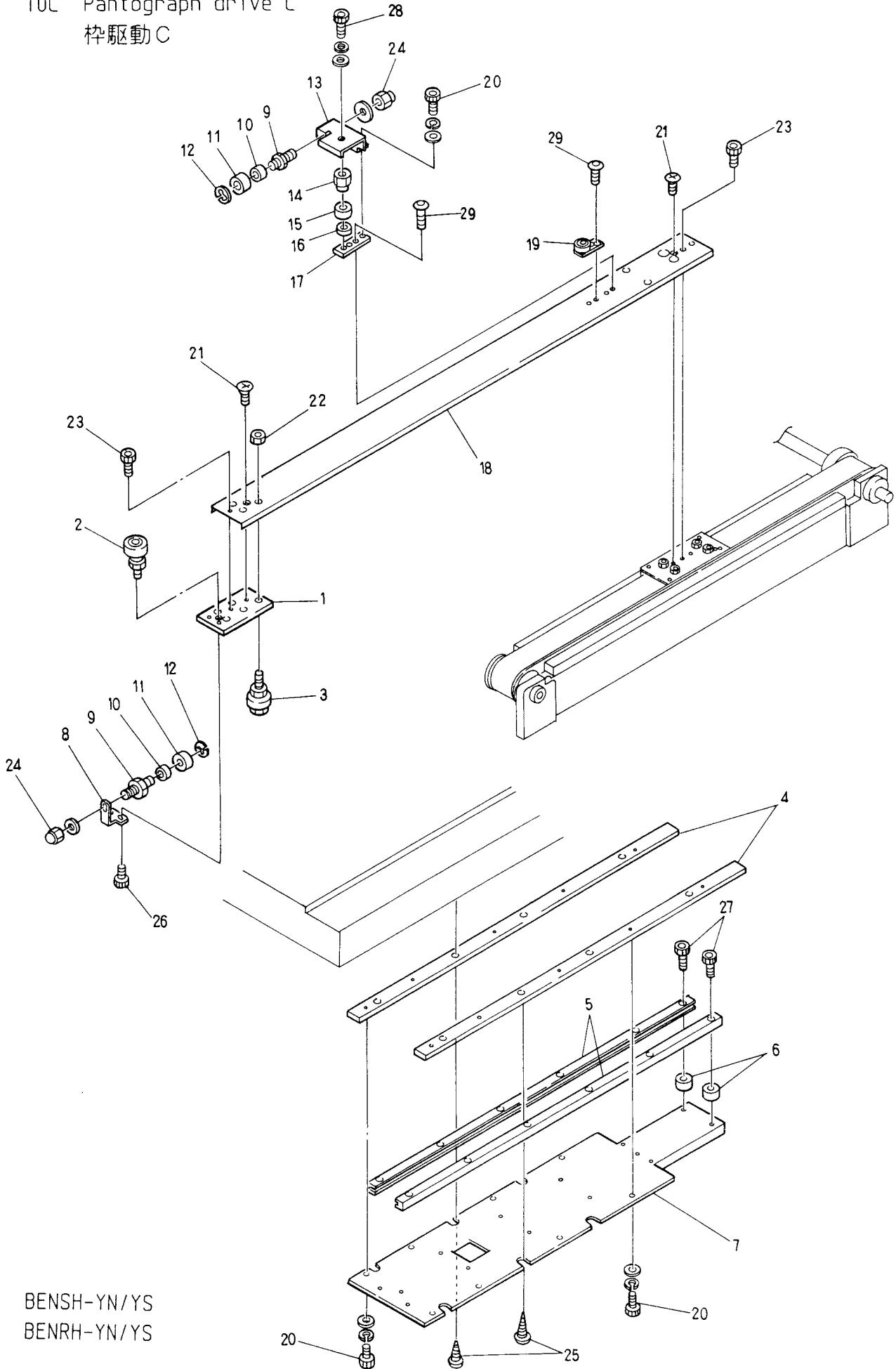

BENSH-YN/YS  
 BENRH-YN/YS









10E-1 Pantograph drive E (2 rails)  
 枠駆動E (2本レール)

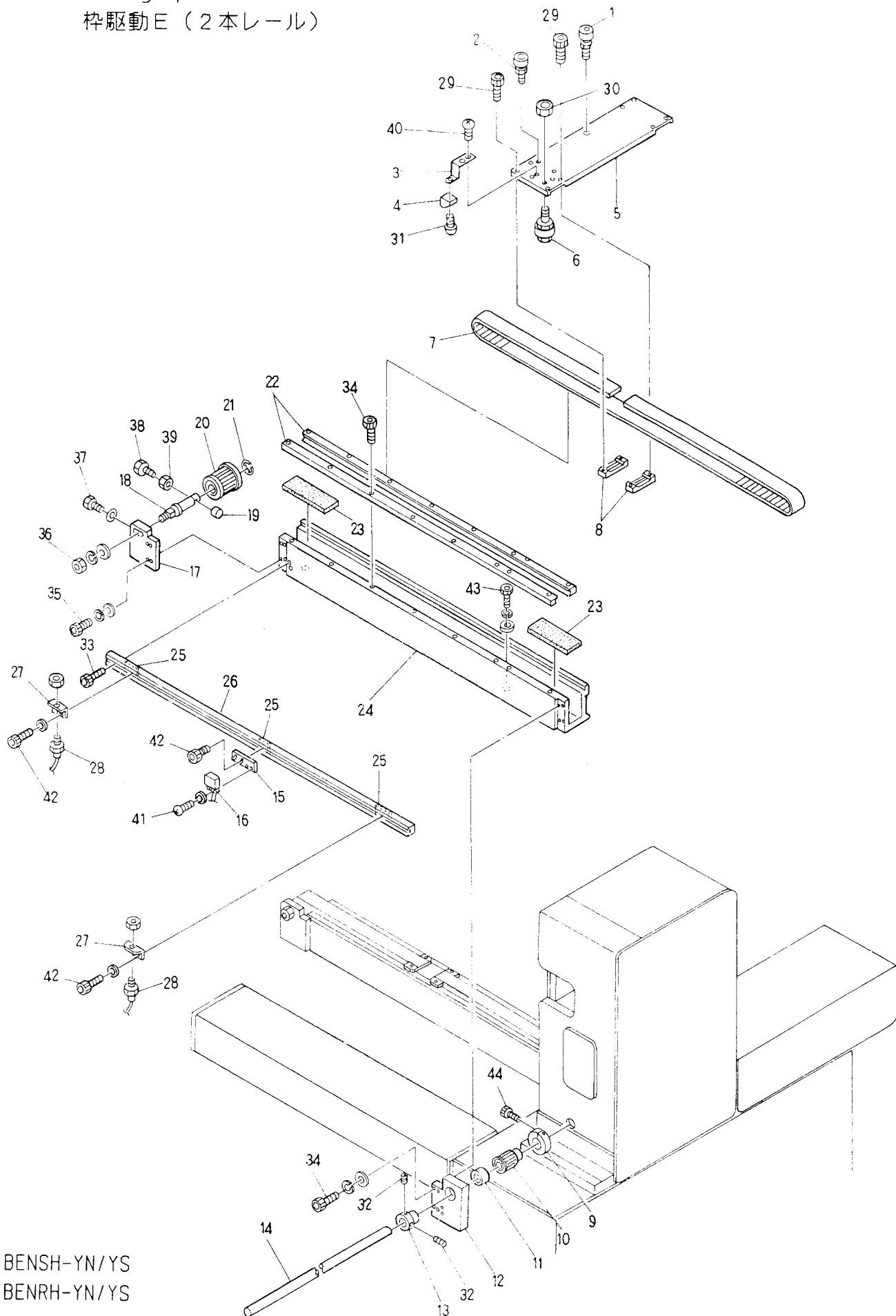

BENSH-YN/YS  
 BENRH-YN/YS

## 10E-1 Pantograph drive E (2 rails)

(\* Depends on machine type)

## 杵駆動 E (2本レール)

(\*は機種によって異なる)

ITEM	LIST No	DESCRIPTION	部品名	Q'TY	NOTE
1	HP483111	Guide bearing pin a'ssy(B)	滑動ベアリングピン a'ssy(B)	1	
2	HP483370	Guide bearing pin a'ssy	滑動ベアリングピン a'ssy	1	
3	HP451100	V-Pantograph origin point magnet bracket	V原点マグネットブラケット	1	
4	A9052030	Magnet(M-102A-02)	マグネット(M-102A-02)	1	
5	HP482892	V-Roller base	Vローラーベース	1	
6	HP482950	Roller pin a'ssy A	ローラーピン組 A	8	
7	A9020098	Timing belt(300S5M2000)	タイミングベルト(300S5M2000)	2	
	A9020178	Timing belt(300S5M2525)	タイミングベルト(300S5M2525)	3~4	H-Stroke 850 over Hストローク850以上
8	HP482940	Timing belt set rack(5M)	タイミングベルト架さえラック(5M)	4	
9	HH481980	Clamping φ19	φ19 割付クランプ	2	
10	HV480040	Pantograph driving pulley(Rear)(S5M)	杵駆動プーリー(後)(S5M)	2	
11	A9011063	Needle bearing(TLA2016)	ニードルベアリング(TLA2016)	2	
12	HV480030	H-Guide rear pulley bracket	H案内後プーリーブラケット	2	
13	HH481970	Pulse motor connecting shaft collar	パルスモーター連結シャフトカラー	2	
14	HV480080	V-Pulse motor connecting shaft (For 2 rails)	Vパルスモーター連結シャフト (2本レール用)	1	
15	KN450300	MH-601A Proximity switch fixing bracket	MH-601A 近接スイッチ取り付けブラケット	1	
16	A9052031	Magnetic proximity switch(MH-601A)	磁気記憶近接スイッチ(MH-601A)	1	
17	HH482000	H-Guide front pulley bracket	H案内前プーリーブラケット	1	
18	HH481991	Timing pulley shaft	従動プーリーシャフト	2	
19	HH482110	Pulley shaft bolt cap	プーリーシャフトボルトキャップ	2	
20	HV480050	Pantograph driving pulley(Front)(S5M)	杵駆動プーリー(前)(S5M)	2	
21	A9012052	E-Ring(φ10)	E型止め輪(φ10)	2	
22	HP482910	V-Guide rail(L=1060)	V溝レール(L=1060)	4	
23	KN480061	Rail base felt(100×38×6)	レール土台フェルト(100×38×6)	4	
24	HP48217G530	V-Guide rail base(Stroke 530)	V案内レール土台(ストローク 530)	2	※
25	KU460270	Plate nut(M3)	板ナット M3	3	
26	HP45112G530	V-Pantograph origin point rail(For V530)	V原点レール (V530用)	1	※
27	MT460240	RS-001 Bracket(V side)	RS-001 ブラケット(V側)	2	
28	A9052024	Switch(RS-001)	スイッチ(RS-001)	2	
29		Hex. socket bolt M3×6	六角穴付ボルト M3×6		
30		Hex. nut M5	六角ナット M5		
31		Truss screw M3×6	十字穴付トラス小ネジ M3×6		
32		Hex. socket set screw M5×8	六角穴付止メネジ M5×8		
33		Hex. socket bolt M4×8	六角穴付ボルト M4×8		
34		Hex. socket bolt M4×15	六角穴付ボルト M4×15		
35		Hex. socket bolt M4×18	六角穴付ボルト M4×18		
36		Hex. nut M8	六角ナット M8		
37		Hex. bolt M4×25	六角ボルト M4×25		
38		Hex. bolt M4×35	六角ボルト M4×35		
39		Hex. nut M1	六角ナット M1		
40		Flush screw M1×8(Undercut)	十字穴付埋小ネジ M1×8(アンダーカット)		
41		Truss screw M3×10	十字穴付トラス小ネジ M3×10		
42		Hex. socket bolt M3×8	六角穴付ボルト M3×8		





10E-2 Pantograph drive E (3 rails)  
 枠駆動E (3本レール)

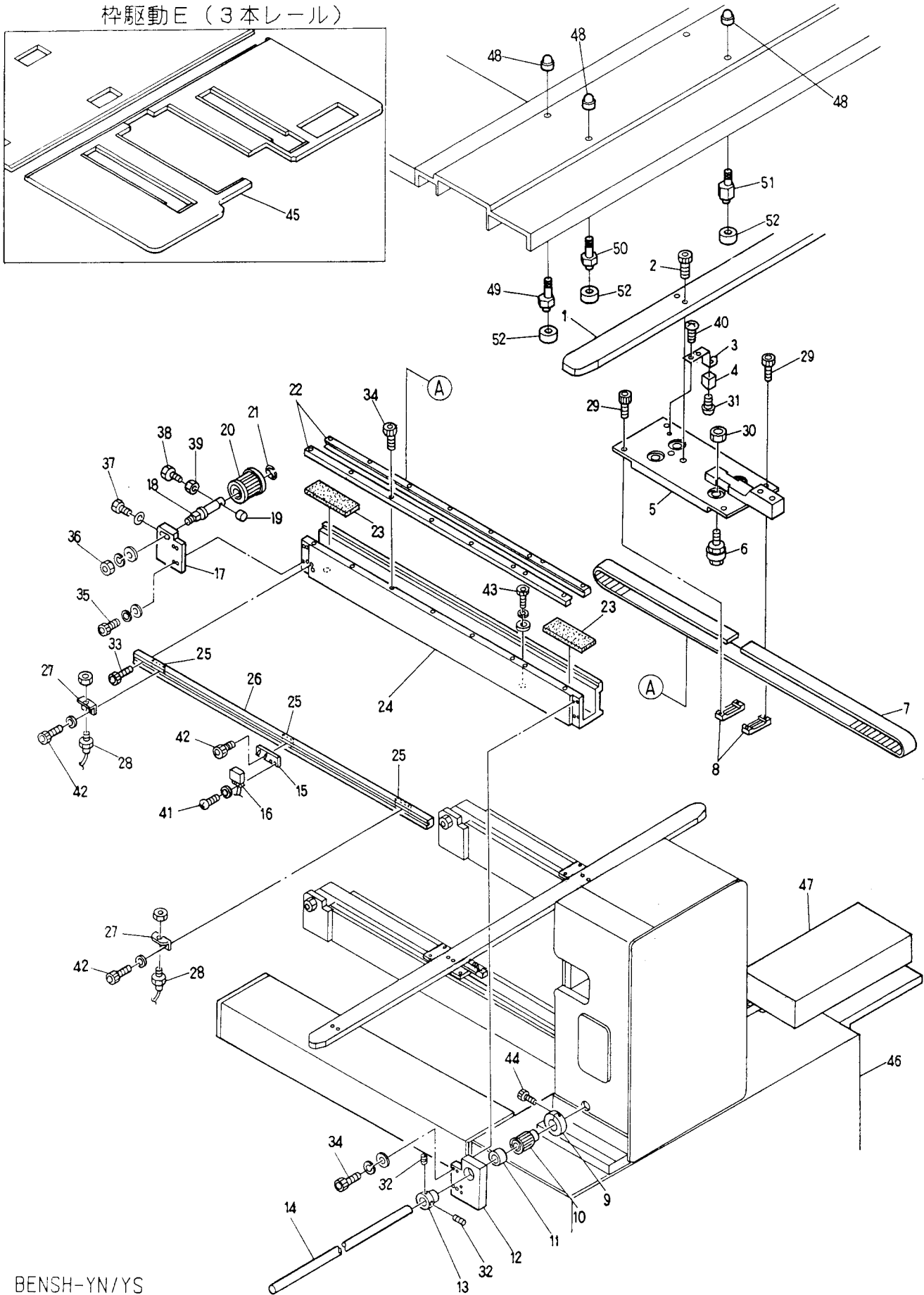

BENSH-YN/YS  
 BENRH-YN/YS

10E-2 Pantograph drive E (3 rails)

(※ Depends on machine type)

枠駆動 E (3本レール)

(※は機種によって異なる)

ITEM	LIST No.	DESCRIPTION	部品名	Q'TY	NOTE
1	HW480110	V-Slide rail	Vスライドレール	1	
2		Hex. Socket bolt M5×15	六角穴付ボルト M5×15		
3	HP451100	V-Pantograph origin point magnet bracket	V枠原点マグネットブラケット	1	
4	A9052030	Magnet(M-102A-02)	マグネット(M-102A-02)	1	
5	HP483341	V-Roller base	Vローラーベース	3	
6	HP482950	Roller pin assy A	ローラーピン組 A	8	
7	A9020098	Timing belt(300S5M2000)	タイミングベルト(300S5M2000)	2	
	A9020178	Timing belt(300S5M2525)	タイミングベルト(300S5M2525)	3~4	H-Stroke 850 over Hストローク850以上
8	HP482940	Timing belt set rack(5M)	タイミングベルト架さえラック(5M)	4	
9	HH481980	Clamping φ19	φ19 割付クランプ	2	
10	HV480040	Pantograph driving pulley(Rear)(S5M)	枠駆動プーリー(後)(S5M)	2	
11	A9011063	Needle bearing(TLA2016)	ニードルベアリング(TLA2016)	2	
12	HV480030	H-Guide rear pulley bracket	H案内後プーリーブラケット	2	
13	HH481970	Pulse motor connecting shaft collar	パルスモーター連結シャフトカラー	2	
14	HV480090	V-Pulse motor connecting shaft (V3 rails)	Vパルスモーター連結シャフト (V3本レール)	1	
15	KN450300	MH-601A Proximity switch fixing bracket	MH-601A 近接スイッチ取り付ブラケット	1	
16	A9052031	Magnetic proximity switch(MH-601A)	磁気記憶近接スイッチ(MH-601A)	1	
17	HH482000	H-Guide front pulley bracket	H案内前プーリーブラケット	1	
18	HH481991	Timing pulley shaft	従動プーリーシャフト	2	
19	HH482110	Pulley shaft bolt cap	プーリーシャフトボルトキャップ	2	
20	HV480050	Pantograph driving pulley(Front)(S5M)	枠駆動プーリー(前)(S5M)	2	
21	A9012052	E-Ring(φ10)	E型止め輪(φ10)	2	
22	HP482910	V-Guide rail(L=1060)	V溝レール(L=1060)	4	
23	KN480061	Rail base felt(100×38×6)	レール土台フェルト(100×38×6)	4	
24	HP48217G530	V-Guide rail base(Stroke 530)	V案内レール土台(ストローク 530)	2	※
25	KU460270	Plate nut(M3)	板ナット(M3)	3	
26	HP45112G530	V-Pantograph origin point rail(For V530)	V枠原点レール(V530用)	1	※
27	MT460240	RS-001 Bracket(V side)	RS-001 ブラケット(V側)	2	
28	A9052024	Switch(RS-001)	スイッチ(RS-001)	2	
29		Hex. socket bolt M3×6	六角穴付ボルト M3×6		
30		Hex. nut M5	六角ナット M5		
31		Truss screw M3×6	十字穴付トラス小ネジ M3×6		
32		Hex. socket set screw M5×8	六角穴付止メネジ M5×8		
33		Hex. socket bolt M4×8	六角穴付ボルト M4×8		
34		Hex. socket bolt M4×15	六角穴付ボルト M4×15		
35		Hex. socket bolt M4×18	六角穴付ボルト M4×18		
36		Hex. nut M8	六角ナット M8		
37		Hex. bolt M4×25	六角ボルト M4×25		
38		Hex. bolt M4×35	六角ボルト M4×35		
39		Hex. nut M4	六角ナット M4		
40		Flush screw M3×8(Undercut)	十字穴付皿小ネジ M3×8(アンダーカット)		
41		Truss screw M3×10	十字穴付トラス小ネジ M3×10		
42		Hex. socket bolt M3×8	六角穴付ボルト M3×8		







10F Pantograph drive F  
枱駆動F

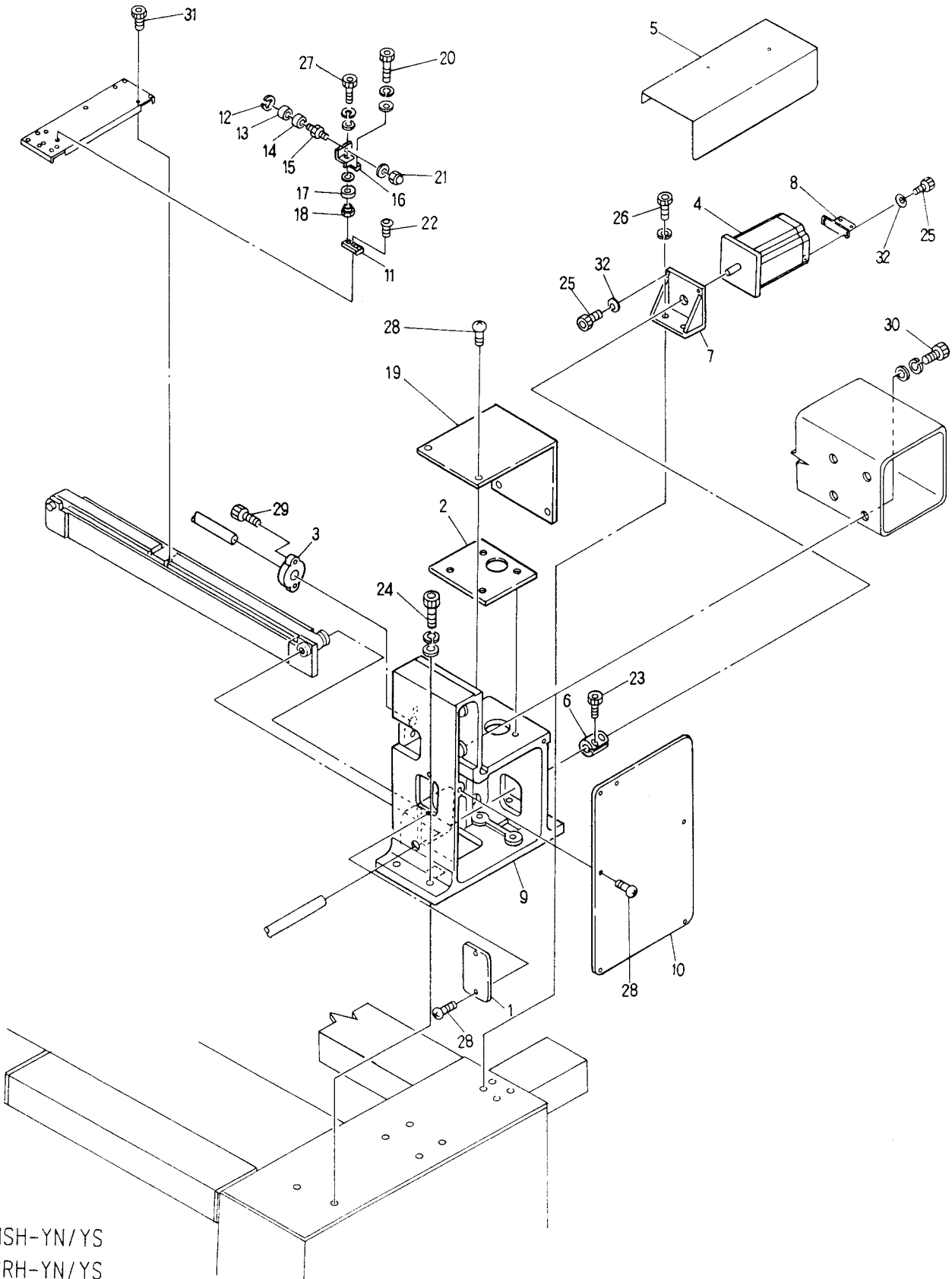

BENSH-YN/YS  
BENRH-YN/YS



11-1 Control (NS)  
制御 (NS)

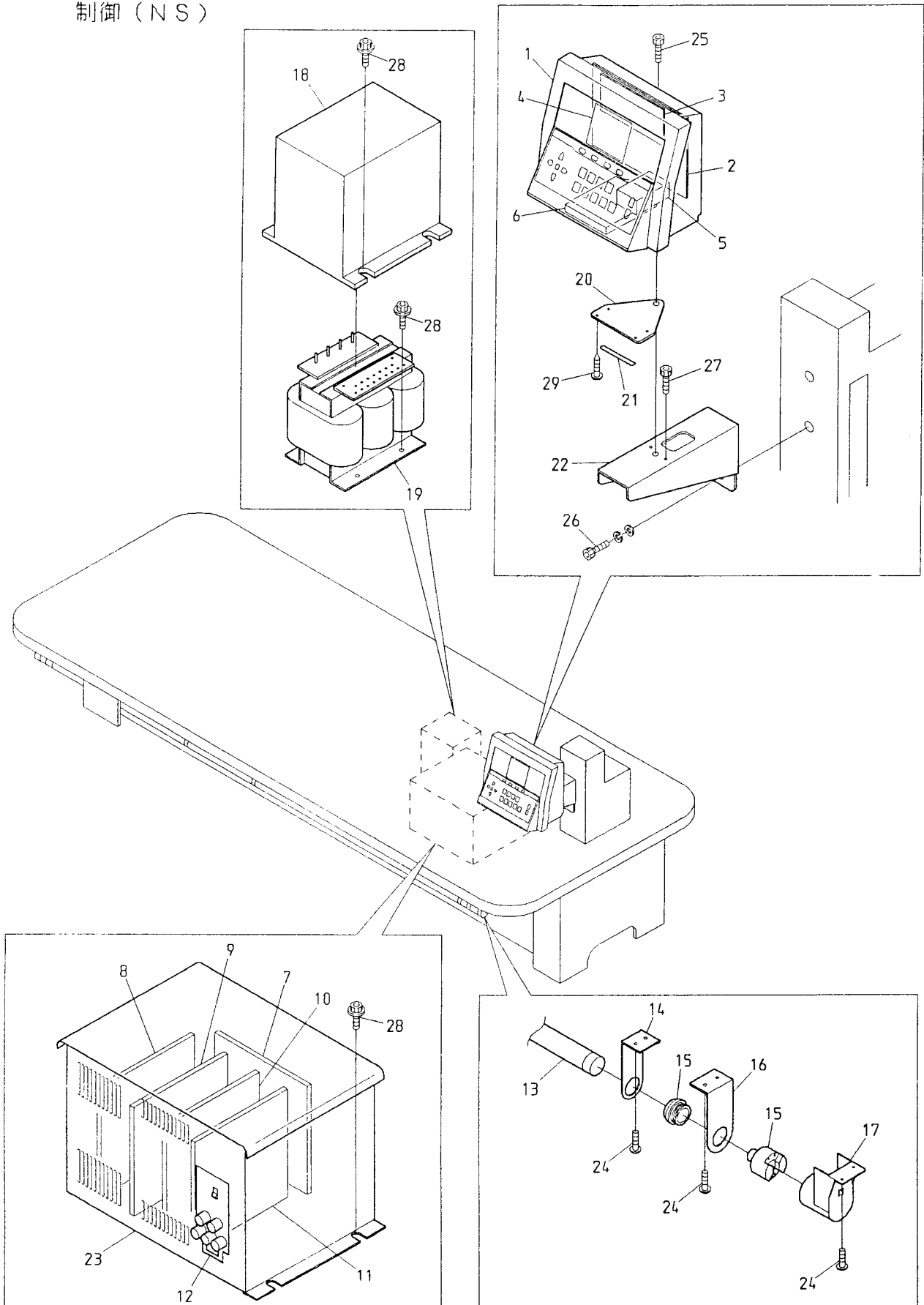

BENSH-YN/YS  
BENRH-YN/YS



11-2 Control (NR)  
制御 (NR)

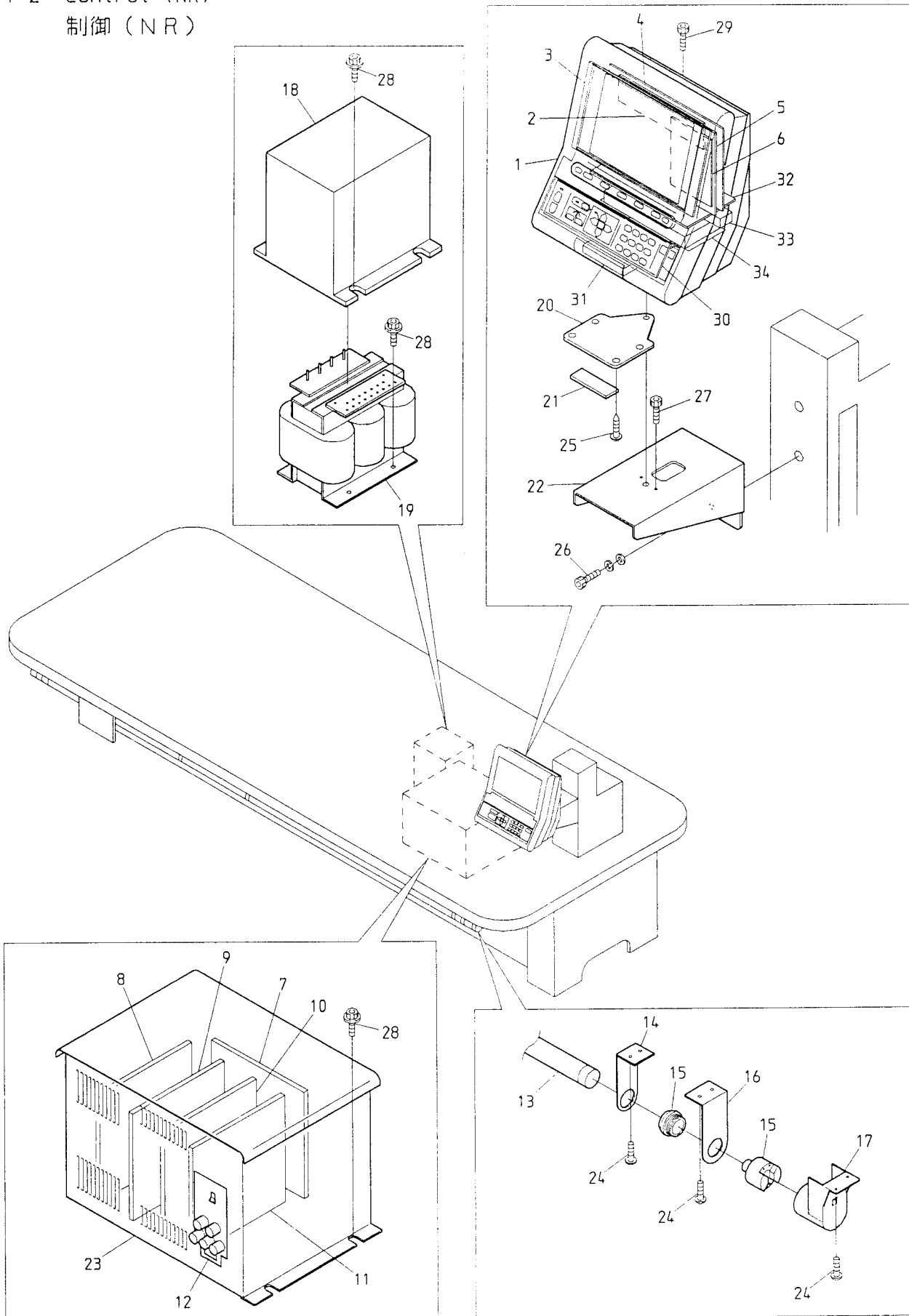

BENSH-YN/YS  
BENRH-YN/YS



12 Accessories  
付属品

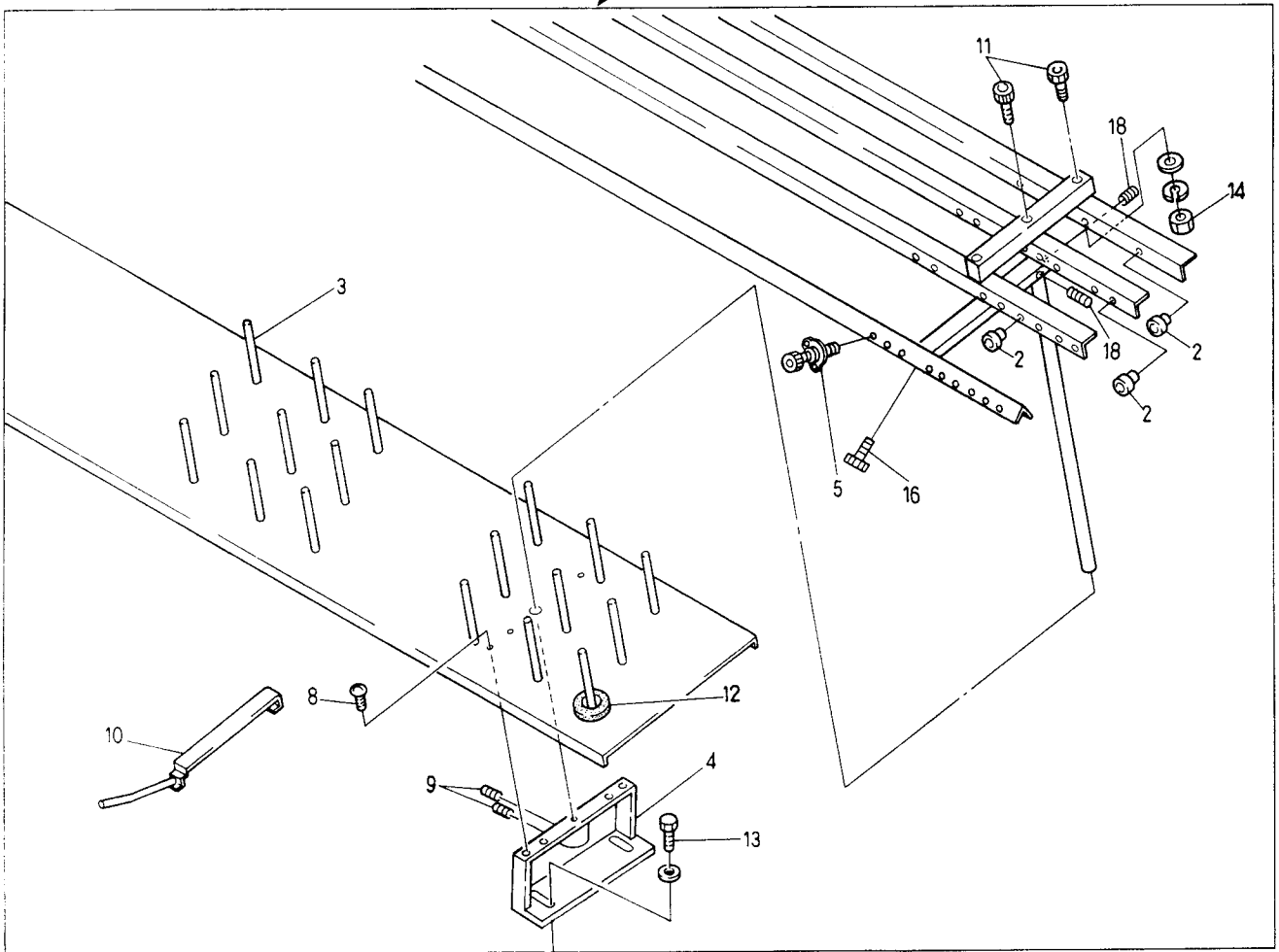
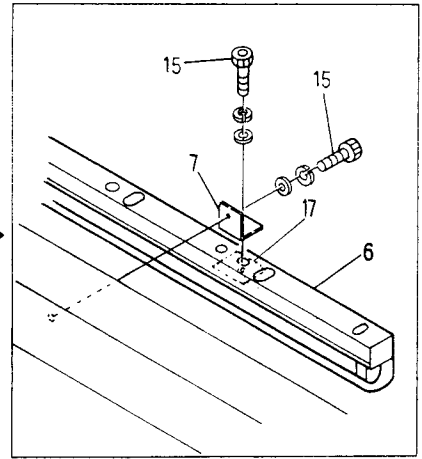
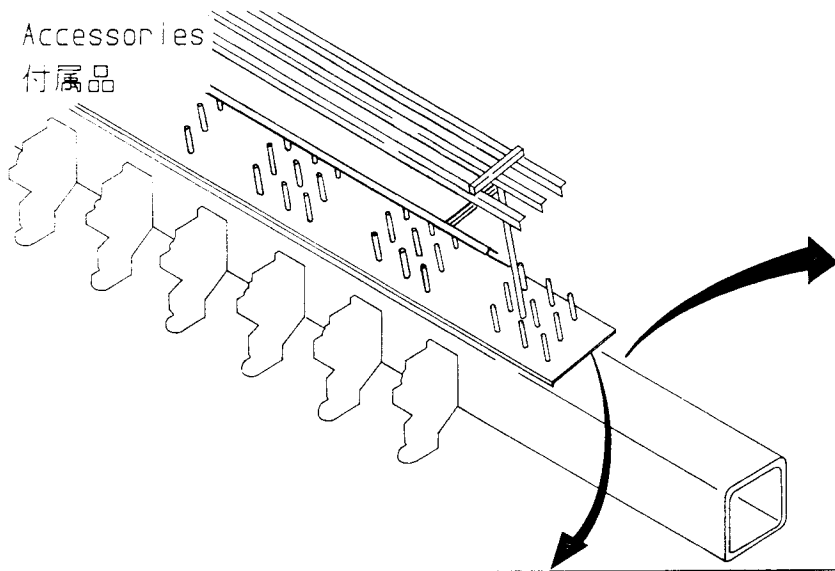

BENSH-YN/YS  
BENRH-YN/YS

BENSHE-YN/YS  
BENRHE-YN/YS







# I N D E X

L I S T No.	SECTION No.	ITEM	L I S T No.	SECTION No.	ITEM
1AHB2024053045G	0 0	4	A 9 0 1 2 1 6 3	0 3 B	1 6
1AHV2030035060H	1 0 E - 2	4 6	A 9 0 1 2 1 6 4	0 4 B	1 0
1BHY3018560045H	0 0	1 7	A 9 0 1 2 2 1 3	0 0	5
1DHV2030035060H	1 0 E - 2	4 5	A 9 0 1 2 2 1 9	1 0 D	1 3
1EHY3018560045H	0 0	2 6	A 9 0 1 2 3 0 6	0 6 B - 2	1 0
1FM2024053045G	1 0 A	3	A 9 0 1 2 3 2 4	0 6 B - 2	9
1KHY3018560045H	0 0	1	A 9 0 1 2 3 6 7	0 4 B	2 7
1SHB20240530J	0 0	7	A 9 0 1 2 3 6 8	0 4 B	1 7
A 9 0 1 0 0 0 1	0 7 B	8	A 9 0 1 3 0 6 6	0 2 C	1 6
A 9 0 1 0 0 1 7	0 3 B	1 5	A 9 0 1 4 0 5 1	0 5	1 4
A 9 0 1 0 0 3 5	1 0 E - 2	5 2	A 9 0 1 4 0 5 5	0 4 A	1 6
A 9 0 1 0 0 6 4	0 2 B	8	A 9 0 2 0 0 9 8	1 0 B	3
A 9 0 1 0 1 0 0	0 1 B	4	A 9 0 2 0 0 9 8	1 0 E - 1	7
A 9 0 1 0 1 0 1	0 1 B	3	A 9 0 2 0 0 9 8	1 0 E - 2	7
A 9 0 1 0 1 0 2	0 1 B	5	A 9 0 2 0 1 3 1	0 8 B	1 9
A 9 0 1 1 0 2 1	0 3 A	5	A 9 0 2 0 1 7 1	0 8 A	1 3
A 9 0 1 1 0 2 1	0 4 A	1 9	A 9 0 2 0 1 7 8	1 0 B	3
A 9 0 1 1 0 2 2	0 4 A	2 0	A 9 0 2 0 1 7 8	1 0 E - 1	7
A 9 0 1 1 0 2 3	0 4 A	1 8	A 9 0 2 0 1 7 8	1 0 E - 2	7
A 9 0 1 1 0 3 5	0 8 B	3	A 9 0 5 2 0 0 5	0 2 B	2
A 9 0 1 1 0 4 0	0 8 A	4	A 9 0 5 2 0 2 4	1 0 D	1 1
A 9 0 1 1 0 4 0	0 8 B	1 5	A 9 0 5 2 0 2 4	1 0 E - 1	2 8
A 9 0 1 1 0 6 3	1 0 B	1 8	A 9 0 5 2 0 2 4	1 0 E - 2	2 8
A 9 0 1 1 0 6 3	1 0 E - 1	1 1	A 9 0 5 2 0 2 8	0 2 C	1 0
A 9 0 1 1 0 6 3	1 0 E - 2	1 1	A 9 0 5 2 0 3 0	1 0 D	6
A 9 0 1 1 1 1 1	0 1 A	1	A 9 0 5 2 0 3 0	1 0 E - 1	4
A 9 0 1 1 1 1 1	0 1 B	2	A 9 0 5 2 0 3 0	1 0 E - 2	4
A 9 0 1 1 1 5 2	0 3 A	4	A 9 0 5 2 0 3 1	1 0 D	1 2
A 9 0 1 2 0 0 1	0 7 A	7	A 9 0 5 2 0 3 1	1 0 E - 1	1 6
A 9 0 1 2 0 0 2	0 7 A	1 4	A 9 0 5 2 0 3 1	1 0 E - 2	1 6
A 9 0 1 2 0 0 2	0 2 B	1 5	A 9 0 5 6 0 1 1	0 7 A	1 5
A 9 0 1 2 0 5 1	0 5	1 5	A 9 0 5 6 0 1 3	0 2 D	1 9
A 9 0 1 2 0 5 2	1 0 B	1 0	A 9 0 5 6 0 1 8	0 2 C	1
A 9 0 1 2 0 5 2	1 0 E - 1	2 1	A 9 0 5 6 0 2 0	0 5	1
A 9 0 1 2 0 5 2	1 0 E - 2	2 1	A 9 0 5 6 0 2 2	0 2 A	9
A 9 0 1 2 0 5 3	0 4 A	3 3	A 9 0 6 5 0 7 4	0 2 B	1 3
A 9 0 1 2 0 5 5	0 7 A	1 8	E A Y 0 3 3 A 1	1 1 - 1	1
A 9 0 1 2 0 5 6	0 2 D	1 2	E A Y 0 3 3 A 2	1 1 - 1	2 3
A 9 0 1 2 0 6 8	0 8 B	1 0	E A Y 0 3 3 A 2	1 1 - 2	2 3
A 9 0 1 2 1 2 6	1 0 C	1 0	E A Y 0 3 3 A 3	1 1 - 1	1 9
A 9 0 1 2 1 2 6	1 0 F	1 4	E A Y 0 3 3 A 3	1 1 - 2	1 9
A 9 0 1 2 1 2 7	1 0 C	1 2	E A Y 0 3 4 A 3	1 1 - 1	1 9
A 9 0 1 2 1 2 7	1 0 F	1 2	E A Y 0 3 4 A 3	1 1 - 2	1 9
A 9 0 1 2 1 4 3	0 7 A	2 2	E A Y 0 3 8 A 1	1 1 - 2	1
A 9 0 1 2 1 5 4	0 1 A	3	E B Y 0 0 9 1 0	0 6 B - 2	5

# I N D E X

L I S T No.	SECTION No.	ITEM	L I S T No.	SECTION No.	ITEM
E B Y 0 0 9 2 0	0 6 B - 2	5	H B 2 3 0 0 7 0	0 3 B	8
E B Y 0 1 1 2 0	0 7 B	4	H B 2 3 0 0 8 0	0 3 B	7
E B Y 0 1 1 5 0	0 6 A - 1	1 2	H B 2 3 0 1 6 0	0 4 B	1 1
E B Y 0 1 2 4 0	1 1 - 1	3	H B 2 3 0 1 8 0	0 4 A	2 4
E B Y 0 1 2 5 0	1 1 - 1	2	H B 2 3 0 1 9 0	0 4 A	3
E B Y 0 1 2 6 0	1 1 - 1	4	H B 2 3 0 2 0 0	0 4 B	1 3
E B Y 0 1 2 7 0	1 1 - 1	5	H B 2 3 0 2 2 0	0 4 C	1 4
E B Y 0 1 2 9 0	1 1 - 1	1 2	H B 2 3 0 2 4 1	0 4 C	9
E B Y 0 1 2 9 0	1 1 - 2	1 2	H B 2 3 0 2 6 1	0 4 C	8
E B Y 0 1 3 0 0	1 1 - 1	1 0	H B 2 3 0 2 7 1	0 4 C	7
E B Y 0 1 3 0 0	1 1 - 2	1 0	H B 2 3 0 2 8 1	0 4 C	1 2
E B Y 0 1 3 1 0	1 1 - 1	8	H B 2 3 0 3 4 1	0 3 B	1 2
E B Y 0 1 3 1 0	1 1 - 2	8	H B 2 3 0 3 5 0	0 4 C	1 0
E B Y 0 1 3 2 0	1 1 - 1	1 1	H B 2 3 0 3 6 0	0 4 C	1 1
E B Y 0 1 3 2 0	1 1 - 2	1 1	H B 2 3 0 6 2 0	0 3 B	4
E B Y 0 1 3 3 0	1 1 - 1	7	H B 2 3 0 6 5 0	0 3 B	3 0
E B Y 0 1 3 3 0	1 1 - 2	7	H B 2 3 0 6 8 1	0 3 B	3 2
E B Y 0 1 3 4 1	1 1 - 1	9	H B 2 3 0 6 9 1	0 3 B	3 2
E B Y 0 1 3 4 1	1 1 - 2	9	H B 2 3 0 7 1 0	0 3 B	3 3
E B Y 0 1 3 5 0	1 1 - 1	6	H B 2 3 0 7 5 0	0 3 A	1 2
E B Y 0 1 3 5 1	1 1 - 2	3 1	H B 2 3 0 8 0 0	0 3 B	2 0
E B Y 0 1 3 8 0	1 1 - 2	3 3	H B 2 4 0 0 1 1	0 5	2
E B Y 0 1 5 3 0	1 1 - 2	5	H B 2 4 0 0 2 0	0 5	4
E B Y 0 1 5 4 1	1 1 - 2	4	H B 2 4 0 0 3 0	0 5	5
E B Y 0 1 5 5 0	1 1 - 2	2	H B 2 4 0 0 4 1	0 5	3
E B Y 0 1 5 6 0	1 1 - 2	3 2	H B 2 4 0 0 6 0	0 5	9
E B Y 0 1 5 7 0	1 1 - 2	3 0	H B 2 4 0 0 7 0	0 5	1 3
E B Y 0 1 5 8 0	1 1 - 2	6	H B 2 4 0 0 8 0	0 5	1 1
E B Y 0 1 5 9 0	1 1 - 2	3 4	H B 2 4 0 0 9 0	0 5	1 0
E B Y 0 1 6 0 1	1 1 - 2	3	H B 2 4 0 1 1 0	0 5	1 2
E B Y 0 1 6 4 0	0 6 A - 2	1 2	H B 2 4 0 1 5 1	0 3 A	2
F N 0 7 0 0 1 1 S N Y	0 4 A	1 2	H B 2 4 0 1 6 0	0 6 A - 2	1 1
H B 1 3 0 0 2 0	0 8 B	2	H B 2 4 0 1 6 1	0 3 A	1 3
H B 1 3 0 0 2 0	1 0 F	2	H B 2 4 0 2 0 0	0 6 A - 1	2 0
H B 1 3 0 0 3 0	0 8 B	2	H B 2 4 0 2 0 0	0 6 A - 2	1 7
H B 1 3 0 0 3 0	1 0 F	2	H B 2 4 0 2 2 0	0 6 A - 1	2 2
H B 1 3 0 0 4 0	0 0	3 3	H B 2 4 0 2 2 0	0 6 A - 2	1 9
H B 1 3 0 0 8 0 4 5	0 0	3 4	H B 2 4 0 2 4 0	0 6 A - 1	2 4
H B 2 2 0 0 1 0	0 1 A	8	H B 2 4 0 2 4 0	0 6 A - 2	2 2
H B 2 3 0 0 1 1	0 3 B	1 3	H B 2 4 0 3 0 0	0 6 A - 1	1 3
H B 2 3 0 0 2 0	0 3 B	1 1	H B 2 4 0 3 0 0	0 6 A - 2	1 3
H B 2 3 0 0 3 0	0 3 B	1 4	H B 2 4 0 3 2 0	0 6 B - 2	8
H B 2 3 0 0 4 0	0 3 B	1 9	H B 2 4 0 3 9 0	0 6 A - 2	3 5
H B 2 3 0 0 5 1	0 3 B	1 0	H B 3 1 0 0 3 0	1 0 F	1 0
H B 2 3 0 0 6 2	0 3 B	9	H B 3 1 0 0 7 0	0 8 A	7

# I N D E X

L I S T No.	SECTION No.	ITEM	L I S T No.	SECTION No.	ITEM
HB 3 1 0 0 7 0	0 8 B	1 6	HH 3 3 0 7 7 0	0 7 A	1 0
HB 3 1 0 0 8 0	0 8 B	9	HH 4 8 1 9 3 1	1 0 D	3
HB 3 1 0 1 0 0	0 8 B	7	HH 4 8 1 9 3 1	1 0 F	6
HB 3 1 0 1 1 0	0 8 A	1	HH 4 8 1 9 7 0	1 0 B	1 9
HB 3 1 0 1 2 0	0 8 B	1 4	HH 4 8 1 9 7 0	1 0 E - 1	1 3
HB 3 1 0 1 4 0	0 8 A	1 1	HH 4 8 1 9 7 0	1 0 E - 2	1 3
HB 3 1 0 1 6 0	0 8 B	6	HH 4 8 1 9 7 0	0 1 B	6
HB 3 1 0 1 6 0	1 0 F	1	HH 4 8 1 9 8 0	1 0 B	1 6
HB 3 1 0 1 8 0	0 8 B	2 0	HH 4 8 1 9 8 0	1 0 E - 1	9
HB 3 1 0 1 8 0	1 0 F	1 9	HH 4 8 1 9 8 0	1 0 E - 2	9
HB 3 1 0 2 8 0	0 8 A	1 5	HH 4 8 1 9 9 1	1 0 B	1 3
HB 3 2 0 0 3 0	0 1 B	1	HH 4 8 1 9 9 1	1 0 E - 1	1 8
HB 3 2 0 0 5 0	0 1 B	1	HH 4 8 1 9 9 1	1 0 E - 2	1 8
HB 3 3 0 0 1 0	0 7 B	1 2	HH 4 8 2 0 0 0	1 0 B	1 4
HB 3 3 0 0 2 0	0 7 B	5	HH 4 8 2 0 0 0	1 0 E - 1	1 7
HB 3 3 0 0 4 0	0 7 A	5	HH 4 8 2 0 0 0	1 0 E - 2	1 7
HB 3 3 0 0 6 0	0 7 A	1 6	HH 4 8 2 0 3 1	1 0 B	4
HB 3 3 0 0 7 0	0 7 A	2	HH 4 8 2 0 4 1	1 0 B	5
HB 3 3 0 0 8 0	0 7 A	1 7	HH 4 8 2 0 9 G 4 5	1 0 B	9
HB 3 3 0 0 9 0	0 7 A	1	HH 4 8 2 1 1 0	1 0 B	1 2
HB 3 3 0 1 0 1	0 7 A	2 1	HH 4 8 2 1 1 0	1 0 E - 1	1 9
HB 3 3 0 1 1 1	0 7 B	9	HH 4 8 2 1 1 0	1 0 E - 2	1 9
HB 3 3 0 1 2 0	0 7 A	3	HK 2 2 0 6 8 1	0 1 A	9
HB 3 3 0 1 3 0	0 7 B	7	HM 3 3 0 0 6 0	0 7 A	2 0
HB 3 3 0 1 4 0	0 7 B	1	HP 1 2 0 0 2 0	0 0	3
HB 3 3 0 1 5 0	0 7 B	1 5	HP 1 2 0 0 3 0	0 0	3 1
HB 3 3 0 1 6 0	0 7 B	6	HP 1 3 0 0 2 1	0 0	2 5
HB 3 3 0 1 8 0	0 7 A	2 6	HP 1 4 0 0 9 0	0 0	1 9
HB 3 3 0 1 9 0	0 7 B	1 4	HP 1 4 0 1 0 0 8 5	0 0	1 8
HB 3 3 0 2 0 0	0 7 B	1 3	HP 1 4 0 1 1 1	0 0	8
HB 3 3 0 2 1 1	0 7 B	1 1	HP 1 4 0 1 2 0	0 0	1 4
HB 3 3 0 2 2 1	0 7 B	1 0	HP 1 4 0 1 7 0	0 0	2 1
HB 5 4 0 0 4 0	0 6 B - 2	1	HP 1 4 0 4 9 0	0 0	1 2
HB 5 4 0 0 5 0	0 6 B - 2	1	HP 1 4 0 8 4 1	0 0	1 1
HB 5 4 0 0 6 0	0 6 B - 2	6	HP 1 4 1 0 8 0	0 0	1 5
HB 5 4 0 0 7 0	0 6 B - 2	6	HP 1 4 1 0 9 0	0 0	2 0
HB 7 1 0 0 1 0	1 2	7	HP 1 4 1 4 5 0	0 0	9
HB 7 1 0 0 2 0	1 2	1 7	HP 2 1 0 3 4 1	0 1 A	1 5
HB 7 9 0 0 3 0	0 6 A - 2	3 4	HP 2 1 1 0 5 0	0 1 A	1 5
HH 1 4 0 2 6 0	0 0	1 0	HP 2 2 0 6 8 0	0 1 A	9
HH 1 4 0 9 4 0	0 0	3 6	HP 2 2 0 7 1 2	0 1 A	4
HH 2 2 0 5 7 0	0 1 A	1 3	HP 2 3 1 3 7 0	0 4 B	2 6
HH 3 2 0 5 5 0	0 8 A	1 0	HP 2 4 1 1 2 2	0 6 A - 2	6
HH 3 3 0 6 7 0	0 7 A	2 5	HP 2 4 1 1 5 1	0 6 A - 2	2
HH 3 3 0 7 6 0	0 2 B	1 6	HP 2 4 1 1 6 0	0 6 A - 2	7

# I N D E X

L I S T No.	SECTION No.	ITEM	L I S T No.	SECTION No.	ITEM
HP 2 4 1 1 8 0	0 6 A - 2	3	HP 4 8 2 5 8 0	1 0 F	1 6
HP 2 4 1 3 8 1	0 6 A - 2	8	HP 4 8 2 5 9 0	1 0 C	1 5
HP 2 4 1 4 1 0	0 6 A - 2	1	HP 4 8 2 8 1 A 4 5	1 0 C	7
HP 2 4 1 4 3 0	1 2	5	HP 4 8 2 8 2 0 4 5	1 0 C	4
HP 2 4 1 4 3 0	0 6 B - 2	1 4	HP 4 8 2 8 7 1	1 0 B	1
HP 2 4 1 4 4 0	0 6 A - 2	5	HP 4 8 2 8 8 1	1 0 C	1
HP 2 4 1 4 5 0	0 6 A - 2	4	HP 4 8 2 8 9 2	1 0 E - 1	5
HP 2 4 1 4 6 0	0 6 A - 2	4	HP 4 8 2 9 0 G 4 5	1 0 A	5
HP 2 4 1 4 8 0	0 6 A - 2	1 0	HP 4 8 2 9 1 0	1 0 B	7
HP 3 1 0 1 5 0	0 8 B	8	HP 4 8 2 9 1 0	1 0 C	5
HP 3 1 0 2 1 0	0 8 A	6	HP 4 8 2 9 1 0	1 0 E - 1	2 2
HP 3 1 0 2 2 0	0 8 A	1 7	HP 4 8 2 9 1 0	1 0 E - 2	2 2
HP 3 2 1 0 8 2	0 1 A	1 6	HP 4 8 2 9 2 1	1 0 C	6
HP 3 2 1 0 9 0	0 1 A	1 7	HP 4 8 2 9 4 0	1 0 B	6
HP 3 2 1 1 0 0	0 8 B	4	HP 4 8 2 9 4 0	1 0 E - 1	8
HP 3 2 1 1 1 0	0 0	2 8	HP 4 8 2 9 4 0	1 0 E - 2	8
HP 3 2 1 1 4 0	1 0 F	3	HP 4 8 2 9 5 0	1 0 B	2
HP 3 2 1 7 1 0	0 1 B	7	HP 4 8 2 9 5 0	1 0 C	3
HP 3 2 1 7 2 0	0 1 B	8	HP 4 8 2 9 5 0	1 0 E - 1	6
HP 3 3 1 5 6 0	0 7 A	1 3	HP 4 8 2 9 5 0	1 0 E - 2	6
HP 3 3 1 6 1 0	0 7 A	1 2	HP 4 8 3 1 1 1	1 0 E - 1	1
HP 3 3 1 6 6 0	0 7 A	8	HP 4 8 3 1 3 G 4 5	1 0 C	1 8
HP 3 3 1 7 0 0	0 7 A	2 3	HP 4 8 3 3 4 1	1 0 E - 2	5
HP 3 3 1 9 2 2	0 1 B	1 0	HP 4 8 3 3 7 0	1 0 C	2
HP 3 3 1 9 5 0	0 7 A	2 4	HP 4 8 3 3 7 0	1 0 E - 1	2
HP 4 5 1 0 8 0	1 0 D	5	HP 4 8 3 3 9 1	1 0 C	1 9
HP 4 5 1 1 0 0	1 0 E - 1	3	HT 2 2 0 0 1 0	0 1 A	1 1
HP 4 5 1 1 0 0	1 0 E - 2	3	HT 2 2 0 0 2 0	0 1 A	1 0
HP 4 5 1 1 1 G 4 5	1 0 D	7	HT 2 2 0 0 3 0	0 1 A	1 0
HP 4 5 1 1 2 G 5 3 0	1 0 E - 1	2 6	HT 2 2 0 0 4 0	0 1 A	5
HP 4 5 1 1 2 G 5 3 0	1 0 E - 2	2 6	HT 2 2 0 0 5 0	0 1 A	5
HP 4 6 0 1 2 1	1 0 C	8	HT 2 3 0 0 1 1	0 3 B	1
HP 4 6 0 1 6 0	1 0 C	1 1	HT 2 3 0 0 2 0	0 3 A	3
HP 4 6 0 1 6 0	1 0 F	1 3	HT 2 3 0 0 3 0	0 3 A	8
HP 4 6 0 1 7 0	1 0 C	9	HT 2 3 0 0 4 1	0 4 A	2 9
HP 4 6 0 1 7 0	1 0 F	1 5	HT 2 3 0 0 6 3	0 4 A	1 7
HP 4 8 2 1 7 G 5 3 0	1 0 E - 1	2 4	HT 2 3 0 0 7 0	0 3 A	9
HP 4 8 2 1 7 G 5 3 0	1 0 E - 2	2 4	HT 2 3 0 0 8 0	0 3 A	1 1
HP 4 8 2 2 5 0	1 0 C	1 3	HT 2 3 0 0 9 0	0 3 B	2
HP 4 8 2 2 6 0	1 0 C	1 6	HT 2 3 0 1 0 0	0 3 B	3
HP 4 8 2 2 7 0	1 0 C	1 4	HT 2 3 0 1 1 1	0 4 A	3 2
HP 4 8 2 2 8 0	1 0 C	1 7	HT 2 3 0 1 2 0	0 4 A	1 0
HP 4 8 2 2 9 0	1 0 F	1 7	HT 2 3 0 1 3 0	0 4 A	2
HP 4 8 2 5 6 0	1 0 F	1 8	HT 2 3 0 1 4 3	0 4 A	8
HP 4 8 2 5 7 0	1 0 F	1 1	HT 2 3 0 1 5 1	0 4 A	2 8

# I N D E X

L I S T No.	SECTION No.	ITEM	L I S T No.	SECTION No.	ITEM
HT 2 3 0 1 7 0	0 3 A	1 0	HT 2 3 0 8 1 0	0 4 A	6
HT 2 3 0 1 8 0	0 4 A	2 2	HT 2 3 0 8 2 0	0 4 A	1
HT 2 3 0 2 1 1	0 3 B	3 1	HT 2 3 0 8 3 0	0 2 D	3 5
HT 2 3 0 2 2 0	0 5	7	HT 2 3 0 8 9 0	0 3 B	5
HT 2 3 0 2 5 1	0 4 A	7	HT 2 3 0 9 0 0	0 3 B	1
HT 2 3 0 2 6 3	0 4 A	3 4	HT 2 3 0 9 3 0	0 4 C	6
HT 2 3 0 2 7 0	0 3 A	1 5	HT 2 4 0 0 0 0	0 3 A	1
HT 2 3 0 2 8 0	0 4 B	2 0	HT 2 4 0 0 1 0	0 3 A	1 4
HT 2 3 0 2 9 0	0 4 B	1 5	HT 2 4 0 0 2 0	0 6 A - 1	9
HT 2 3 0 3 0 0	0 3 A	6	HT 2 4 0 0 6 2	0 6 A - 1	1 0
HT 2 3 0 3 2 0	0 4 B	2	HT 2 4 0 1 0 0	0 6 B - 1	1
HT 2 3 0 3 3 0	0 4 A	3 0	HT 2 4 0 1 2 0	0 6 A - 1	1
HT 2 3 0 3 4 0	0 4 B	3	HT 2 4 0 1 3 0	0 6 A - 1	2
HT 2 3 0 3 6 1	0 2 D	2 3	HT 2 4 0 1 4 0	0 6 A - 1	3
HT 2 3 0 3 7 0	0 4 B	4	HT 2 4 0 1 5 1	0 6 A - 1	4
HT 2 3 0 3 8 0	0 4 C	4	HT 2 4 0 1 6 0	0 6 A - 1	5
HT 2 3 0 4 1 0	0 4 C	1 3	HT 2 4 0 1 7 1	0 6 A - 1	6
HT 2 3 0 4 2 0	0 4 C	5	HT 2 4 0 1 8 0	0 6 A - 1	7
HT 2 3 0 4 5 0	0 4 B	6	HT 2 4 0 2 1 1	0 6 A - 1	1 5
HT 2 3 0 4 6 0	0 4 B	7	HT 2 4 0 2 2 0	0 6 A - 1	1 6
HT 2 3 0 4 7 0	0 4 B	1 4	HT 2 4 0 2 3 0	0 6 A - 1	1 7
HT 2 3 0 4 8 0	0 4 B	8	HT 2 4 0 2 4 0	0 6 A - 1	1 9
HT 2 3 0 4 9 0	0 4 B	1	HT 2 4 0 2 5 0	0 6 B - 1	2
HT 2 3 0 5 0 0	0 4 B	5	HT 2 4 0 2 7 0	0 6 B - 1	3
HT 2 3 0 5 1 0	0 4 B	1 2	HT 2 4 0 2 8 0	0 6 B - 1	4
HT 2 3 0 5 2 0	0 4 B	1 6	HT 2 4 0 2 9 0	0 6 B - 1	5
HT 2 3 0 5 3 0	0 4 B	1 9	HT 2 4 0 3 0 0	0 6 B - 1	6
HT 2 3 0 5 4 0	0 3 A	7	HT 2 4 0 3 1 0	0 6 B - 1	7
HT 2 3 0 5 5 0	0 4 A	2 1	HT 2 4 0 3 3 1	0 6 A - 1	1 8
HT 2 3 0 5 6 0	0 4 B	2 1	HT 2 4 0 3 4 0	0 6 B - 1	9
HT 2 3 0 5 7 0	0 4 A	1 4	HT 2 4 0 3 9 1	0 6 A - 1	1 1
HT 2 3 0 5 8 0	0 3 B	1 7	HT 2 4 0 4 3 0	0 6 A - 1	2 3
HT 2 3 0 5 9 0	0 4 C	1 5	HT 2 4 0 4 3 0	0 6 A - 2	2 1
HT 2 3 0 6 0 0	0 4 C	3	HT 2 4 0 4 4 0	0 6 A - 1	2 5
HT 2 3 0 6 1 0	0 4 C	1	HT 2 4 0 4 4 0	0 6 A - 2	2 3
HT 2 3 0 6 2 0	0 5	8	HT 2 4 0 4 6 0	0 6 A - 1	2 1
HT 2 3 0 6 3 1	0 5	6	HT 2 4 0 4 6 0	0 6 A - 2	1 8
HT 2 3 0 6 6 0	0 3 B	1 8	HT 2 4 0 4 7 0	0 6 A - 1	2 6
HT 2 3 0 6 7 0	0 4 A	1 1	HT 2 4 0 5 2 4	0 6 A - 1	1 4
HT 2 3 0 6 9 0	0 4 A	1 5	HT 2 7 0 0 0 1	0 2 D	2
HT 2 3 0 7 2 0	0 4 C	2	HT 2 7 0 0 1 0	0 2 D	2 2
HT 2 3 0 7 3 0	0 4 B	1 8	HT 2 7 0 0 2 1	0 2 D	5
HT 2 3 0 7 5 0	0 4 B	2 3	HT 2 7 0 0 3 0	0 2 D	1
HT 2 3 0 7 6 0	0 4 B	9	HT 2 7 0 0 4 0	0 2 D	4
HT 2 3 0 7 7 0	0 4 B	2 2	HT 2 7 0 0 6 2	0 2 D	2 5

# I N D E X

L I S T No.	SECTION No.	ITEM	L I S T No.	SECTION No.	ITEM
HT 2 7 0 0 7 0	0 2 C	3	HV 3 3 0 0 3 0	1 1 - 2	2 2
HT 2 7 0 0 8 0	0 2 D	1 1	HV 3 3 0 0 4 0	1 1 - 2	2 0
HT 2 7 0 0 9 0	0 2 D	1 4	HV 4 8 0 0 1 0	1 0 D	2
HT 2 7 0 1 0 0	0 2 D	1 0	HV 4 8 0 0 1 0	1 0 F	7
HT 2 7 0 1 1 0	0 2 C	1 4	HV 4 8 0 0 2 0	1 0 D	4
HT 2 7 0 1 2 0	0 2 D	9	HV 4 8 0 0 2 0	1 0 F	8
HT 2 7 0 3 5 0	0 2 D	2 4	HV 4 8 0 0 3 0	1 0 B	1 5
HT 2 7 0 6 4 0	0 2 D	2 0	HV 4 8 0 0 3 0	1 0 E - 1	1 2
HT 3 3 0 0 0 1	0 7 A	4	HV 4 8 0 0 3 0	1 0 E - 2	1 2
HT 7 1 0 0 0 0	1 2	3	HV 4 8 0 0 4 0	1 0 B	1 7
HV 2 4 0 0 0 0	0 6 A - 1	3 9	HV 4 8 0 0 4 0	1 0 E - 1	1 0
HV 2 5 0 0 1 0	0 2 A	1	HV 4 8 0 0 4 0	1 0 E - 2	1 0
HV 2 7 0 0 2 0	0 2 A	1 3	HV 4 8 0 0 5 0	1 0 B	1 1
HV 2 7 0 0 3 0	0 2 A	1 0	HV 4 8 0 0 5 0	1 0 E - 1	2 0
HV 2 7 0 0 4 0	0 2 A	4	HV 4 8 0 0 5 0	1 0 E - 2	2 0
HV 2 7 0 0 5 0	0 2 A	6	HV 4 8 0 0 6 0	1 0 D	1
HV 2 7 0 0 6 0	0 2 A	3	HV 4 8 0 0 6 0	1 0 F	4
HV 2 7 0 0 7 0	0 2 A	5	HV 4 8 0 0 7 0	1 0 A	7
HV 2 7 0 0 8 0	0 2 A	2	HV 4 8 0 0 8 0	1 0 E - 1	1 4
HV 2 7 0 0 9 0	0 2 A	7	HV 4 8 0 0 9 0	1 0 E - 2	1 4
HV 2 7 0 1 0 0	0 2 A	1 2	HV 4 8 2 2 1 G 5 3 0	1 0 A	6
HV 2 7 0 2 0 0	0 2 B	7	HV 5 1 0 0 1 0	1 1 - 1	2 2
HV 2 7 0 2 1 0	0 2 B	4	HV 5 1 0 0 2 0	1 0 D	2 5
HV 2 7 0 2 2 0	0 2 B	1 1	HV 7 1 0 0 1 0	1 2	6
HV 2 7 0 2 3 0	0 2 B	6	HV 7 1 0 0 2 0	1 2	6
HV 2 7 0 2 4 0	0 2 B	1 0	HW 1 4 0 0 3 0	0 0	4 5
HV 3 1 0 0 1 0	1 0 F	9	HW 1 4 0 0 4 0	0 0	4 3
HV 3 1 0 0 2 0	0 8 B	1	HW 1 4 0 0 5 0	0 0	4 4
HV 3 1 0 0 3 0	0 0	2 7	HW 4 8 0 0 5 0	1 0 E - 2	5 1
HV 3 1 0 0 4 0	0 8 A	9	HW 4 8 0 0 7 0	1 0 E - 2	5 0
HV 3 1 0 0 5 0	0 8 A	1 6	HW 4 8 0 0 8 0	1 0 E - 2	4 9
HV 3 1 0 0 6 0	0 8 B	1 7	HW 4 8 0 1 1 0	1 0 E - 2	1
HV 3 1 0 0 7 0	0 8 A	8	KB 2 4 0 0 6 0	0 6 A - 2	1 6
HV 3 1 0 0 7 0	0 8 B	1 8	KB 2 4 0 1 0 0	0 6 A - 2	1 5
HV 3 1 0 0 8 0	0 8 B	1 3	KC 1 4 0 1 2 1	0 0	2 3
HV 3 1 0 0 9 0	0 8 B	1 2	KC 2 7 0 1 0 1	0 2 D	1 8
HV 3 1 0 1 0 0	0 8 B	1 1	KC 2 7 0 2 7 1	0 2 D	6
HV 3 1 0 1 1 0	0 8 A	3	KC 2 7 0 2 9 2	0 2 D	7
HV 3 1 0 1 2 0	0 8 A	1 2	KC 2 7 1 4 4 0	0 2 B	1
HV 3 1 0 1 3 0	1 0 F	5	KC 3 2 0 8 2 0	0 8 A	2
HV 3 1 0 1 4 0	1 0 D	2 6	KC 3 2 0 8 2 0	0 8 B	5
HV 3 1 0 1 6 0	1 0 E - 2	4 7	KC 3 3 0 1 7 0	0 7 B	3
HV 3 3 0 0 1 1	1 1 - 1	2 0	KC 3 3 0 1 8 0	0 2 B	3
HV 3 3 0 0 2 2	1 1 - 1	2 1	KC 3 3 0 2 8 0	0 7 B	2
HV 3 3 0 0 2 2	1 1 - 2	2 1	KC 3 3 0 3 1 0 3 0 0	0 7 A	6



# I N D E X

L I S T No.	SECTION No.	ITEM	L I S T No.	SECTION No.	ITEM
K C 3 3 0 4 1 0	0 7 A	9	K L 2 7 0 0 0 0	0 2 D	8
K C 3 3 0 4 1 0	0 2 B	1 7	K L 2 7 0 0 4 0	0 2 D	1 3
K C 3 3 0 4 1 0	0 4 A	5	K L 2 7 0 0 6 0	0 2 D	1 5
K C 3 3 0 4 2 0	0 7 A	1 1	K L 2 7 0 0 7 0	0 2 D	1 7
K C 5 2 0 0 2 0	1 1 - 1	1 8	K L 2 7 0 0 8 1	0 2 C	2
K C 5 2 0 0 2 0	1 1 - 2	1 8	K L 2 7 0 0 9 1	0 2 C	1 1
K C 5 3 0 2 3 0	1 1 - 1	1 6	K L 2 7 0 1 0 1	0 2 C	5
K C 5 3 0 2 3 0	1 1 - 2	1 6	K L 2 7 0 1 1 0	0 2 C	8
K C 5 3 0 2 4 0	1 1 - 1	1 4	K L 2 7 0 1 2 0	0 2 C	7
K C 5 3 0 2 4 0	1 1 - 2	1 4	K L 2 7 0 1 3 0	0 2 C	6
K F 2 2 0 3 0 2	0 1 A	6	K L 2 7 0 2 6 0	0 2 C	9
K F 2 2 0 4 1 1	0 1 A	7	K L 2 7 0 4 0 0	0 2 C	1 3
K F 2 2 0 4 2 1	0 1 A	7	K L 2 7 0 4 5 0	0 2 C	1 2
K F 2 2 0 4 4 0	0 1 A	6	K L 2 7 0 5 2 0	0 2 D	1 6
K F 2 2 0 5 1 1	0 1 A	1 4	K N 2 7 1 7 2 0	0 2 B	1 2
K F 2 2 0 7 8 0	0 1 A	8	K N 2 7 1 7 5 0	0 2 B	9
K F 2 3 0 2 4 0	0 4 A	1 3	K N 2 7 1 7 8 2	0 2 B	8
K F 2 3 0 5 0 0	0 3 B	6	K N 2 7 1 8 0 0	0 2 B	1 4
K F 2 3 0 5 3 0	0 4 B	2 5	K N 2 7 2 3 5 0	0 2 B	5
K F 2 3 0 5 8 2	0 2 D	3	K N 2 7 2 4 0 0	0 2 A	1 1
K F 2 3 0 6 3 0	0 7 A	1 9	K N 2 7 2 4 0 0	0 2 C	4
K F 2 3 0 6 4 0	0 2 A	8	K N 2 7 2 4 0 0	0 2 D	2 1
K F 2 3 0 6 4 0	0 4 A	4	K N 3 1 0 0 1 0	0 8 A	1 4
K F 2 3 0 6 6 1	0 4 A	2 6	K N 3 1 3 6 7 0	0 8 A	5
K F 2 3 0 6 7 0	0 4 A	2 7	K N 4 5 0 3 0 0	1 0 D	1 0
K F 2 3 0 9 1 0	0 4 A	9	K N 4 5 0 3 0 0	1 0 E - 1	1 5
K F 2 4 0 9 0 0	1 2	2	K N 4 5 0 3 0 0	1 0 E - 2	1 5
K F 2 5 0 2 2 0	0 2 D	3 6	K N 4 8 0 0 6 1	1 0 B	8
K F 2 5 0 2 3 1	0 2 D	3 8	K N 4 8 0 0 6 1	1 0 E - 1	2 3
K F 2 5 0 2 4 1	0 2 D	3 7	K N 4 8 0 0 6 1	1 0 E - 2	2 3
K F 2 5 0 2 5 0	0 2 D	3 9	K N 4 8 0 3 5 0 5 6 0	1 0 A	2
K F 2 5 0 9 0 0	0 2 A	1 4	K N 4 8 0 3 5 0 6 1 0	1 0 A	4
K F 3 3 0 1 8 0	0 4 A	2 3	K N 4 8 0 4 2 0 5 6 0	1 0 A	1 4
K F 5 3 0 1 1 1	1 1 - 1	1 5	K N 5 1 1 0 2 0	0 1 B	9
K F 5 3 0 1 1 1	1 1 - 2	1 5	K N 5 4 0 5 0 0	0 6 B - 2	2
K F 5 3 0 1 2 0	1 1 - 1	1 5	K N 5 4 0 5 1 0	0 6 B - 1	8
K F 5 3 0 1 2 0	1 1 - 2	1 5	K N 5 4 0 5 1 0	0 6 B - 2	4
K F 5 3 0 1 5 0	1 1 - 1	1 7	K N 5 4 0 5 2 0	0 6 B - 2	3
K F 5 3 0 1 5 0	1 1 - 2	1 7	K N 5 4 0 7 6 0	0 6 B - 2	7
K F 5 3 0 1 6 0	1 1 - 1	1 3	K U 2 4 1 4 0 0	0 6 A - 2	1 4
K F 5 3 0 1 6 0	1 1 - 2	1 3	K U 4 6 0 2 7 0	1 0 D	8
K F 7 1 0 3 9 0	1 2	1 2	K U 4 6 0 2 7 0	1 0 E - 1	2 5
K F 7 3 0 7 9 0	1 0 A	1	K U 4 6 0 2 7 0	1 0 E - 2	2 5
K G 2 5 0 0 1 0	0 6 A - 2	2 0	M T 4 6 0 2 4 0	1 0 D	9
K L 2 3 0 1 8 0	0 4 A	2 5	M T 4 6 0 2 4 0	1 0 E - 1	2 7

